

# SPECIFICATION SHEET MODEL 826YD (2½" -10")

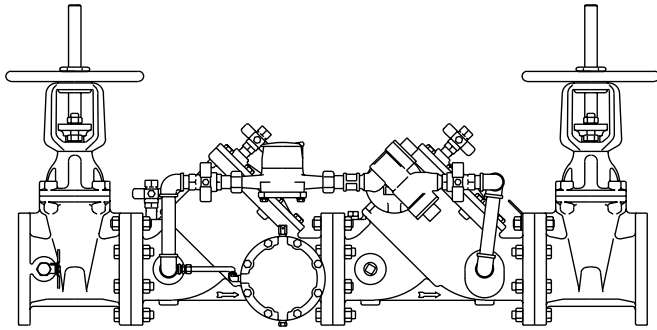

## Reduced Pressure Detector Assembly



FEBCO MODEL 826YD (2½" - 10")

### Features

- The **DuraCheck**, features all stainless steel check assemblies for corrosion resistance, reduced fouling and longer valve life.
- **DuraCast**, ductile iron body for superior strength, corrosion resistance and lighter weight. By-pass line has water meter in series with an approved reduced pressure assembly.
- Low Head Loss
- **Approved by the Foundation for Cross Connection Control and Hydraulic Research at the University of Southern California.**

### Operation

In a nonflow condition check valves on the by-pass and mainline units are closed with pressure between the checks, called the zone, being maintained at least 5 PSI lower than the inlet pressure and the relief valve is maintained closed. If the differential between the zone and the upstream pressure drops to 2 PSI, the differential relief valve will open, maintaining proper zone differential. The by-pass reduced pressure backflow preventer will operate identically to the mainline assembly.

The by-pass opens to detect initial flow and the mainline opens for all other flows.

### Typical Applications

Automatic fire sprinkler systems containing toxic substances.

### Specification

Reduced pressure detector assembly shall consist of a mainline reduced pressure configured backflow assembly in parallel with a reduced pressure by-pass assembly.

Flow curves shall be documented by independent laboratory testing. Mainline valve bodies and covers shall be manufactured of ductile iron ASTM A-536, Grade 65-45-12 and shall be flanged, ANSI B 16.1, Class 125, internal and external fusion epoxy coating.

The by-pass shall consist primarily of a bronze water meter in series with a bronze reduced pressure backflow preventer.

All low flow demands up to a minimum of 3 GPM (0.189 L/s) are to pass only through the by-pass meter and meter-size reduced pressure assembly and be accurately recorded. All flows above that of 3 GPM will pass through both the line-size reduced pressure assembly and by-pass without accurate registration by or damage to the meter.

Shut-off valves and testcocks shall be resilient seated with full flow characteristics and are to be considered integral to the assembly. The mainline shut-offs are also to be OS & Y, UL/FM for fireline service.

Reduced pressure detector assemblies shall be rated 175 PSI CWWP (32°F to 140°F), factory assembled and tested to assure proper mainline/by-pass balance and cross over performance. Reduced pressure detector assemblies shall be FEBCO Model 826YD or prior approved equal.

### Agency Compliance

Approved by the Foundation for Cross-Connection Control and Hydraulic Research at the University of Southern California.\*

ASSE Listed (Std. 1047-1990)

UL Listed\*

FM Approved\*\*

\* Valves must be supplied with resilient seated shut-off valves for USC and FM approvals to be in effect.

• UL and FM Listings only applicable with approved OS&Y gates.

### Installation

The Reduced Pressure Detector Assembly should be installed horizontally with a suggested minimum clearance of 12" between the assembly and the floor or grade. They must be installed where discharge from the relief valve will not be objectionable and can be positively drained away. They should be installed where easily accessible for testing and maintenance and must be protected from freezing. Thermal water expansion and/or water hammer downstream of the backflow preventer can cause excessive pressure. Excessive pressure situations should be eliminated to avoid possible damage to the system and assembly.

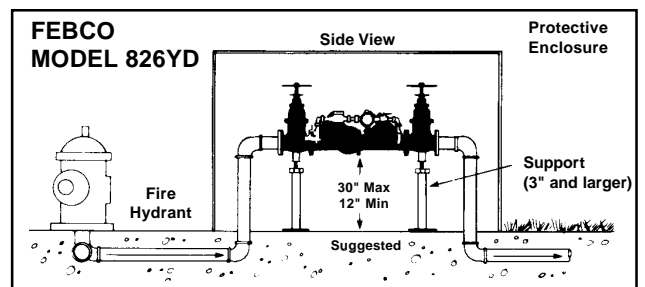

## Dimensions and Weights\* (U.S.-Inches)

(U.S. - Inches)						Net Wt. (lbs)	
SIZE	A	B	C	D**	E	GV	LG
2 1/2	37 1/4	22 1/8	7 1/2	16 3/8	10 1/4	243.0	134.0
3	41 3/4	25 5/8	8 1/2	22 1/4	10 1/2	298.0	154.0
4	50 7/16	32 3/8	11	23 1/4	11	469.0	194.0
6	59 3/4	38 5/8	14	30 1/8	12	752.0	397.0
8	69 3/16	46 1/8	18	37 3/4	13	1207.0	537.0
10	84 1/4	58 1/8	22	48	14	1617.0	957.0

(Metric - MM)						Net Wt. (kgs)	
SIZE	A	B	C	D**	E	GV	LG
65	946.2	562.0	190.5	415.9	260.4	534.6	294.8
80	1060.5	650.9	215.9	565.2	266.7	655.6	338.8
100	1281.1	822.3	279.4	590.6	279.4	1031.8	426.8
150	1517.7	981.1	355.6	765.2	304.8	1654.4	873.4
200	1757.4	1171.6	457.2	958.9	330.2	2655.4	1181.4
250	2140.0	1476.4	558.8	1219.2	355.6	3557.4	2105.4

\* Applies to OS&Y gated units only. Subject to manufacturing tolerance.

\*\* Varies per manufacturer.

## Characteristics and Materials

Sizes	Mainline: 2 1/2", 3", 4", 6", 8", 10" By-pass: 3/4"
Maximum working pressure	175 PSI (1200 KPa)
Hydrostatic test pressure	350 PSI (2400 KPa)
Temperature range	32°F to 140°F (0°C to 60°C)
Fluid	Water
End detail	Flanged
Main valve body	Ductile iron grade 65-45-12
epoxy coated internal	10-20 mils
Internal check assembly	Stainless steel
Trim	Bronze
By-pass valve body	Bronze
By-pass meter	Totalizing, 1 to 20 gpm size 5/8" x 3/4"
Mainline shut-off valves	OS&Y, UL/FM
Elastomers:	Nitrile Diaphragm: Nitrile, fabric reinforced

Remote reading  
flow meter available

### Options

- Less Gates
- Remote Reading
- Air gap drain
- Meter CFPM
- Left hand by-pass

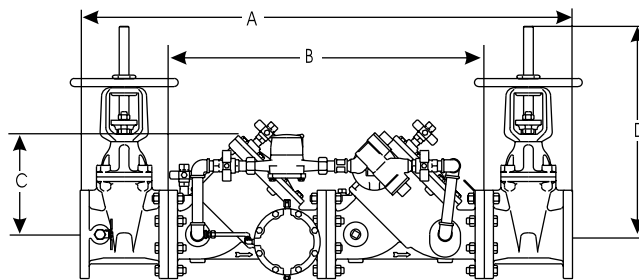
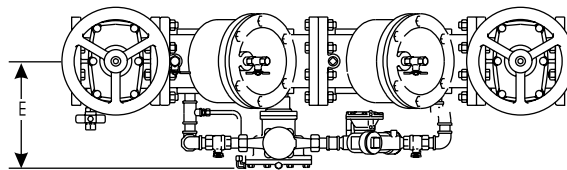

## Model 826YD Flow Curves

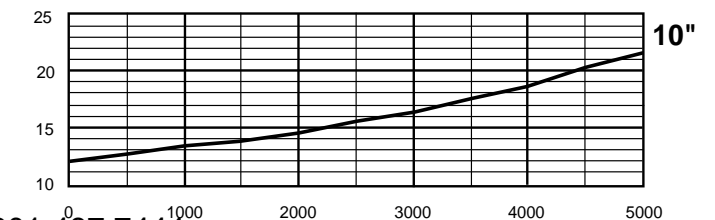
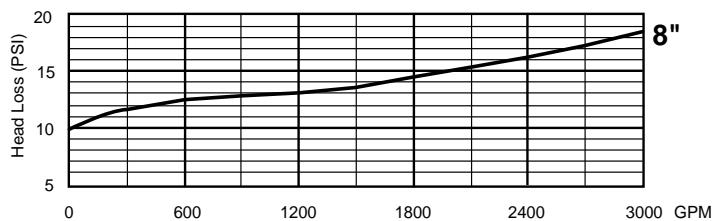
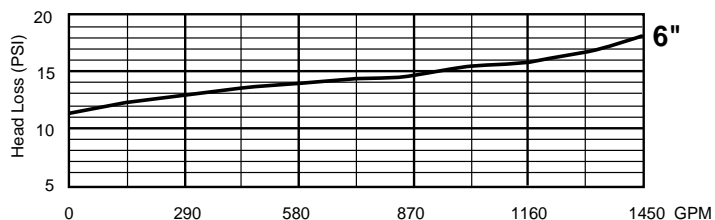
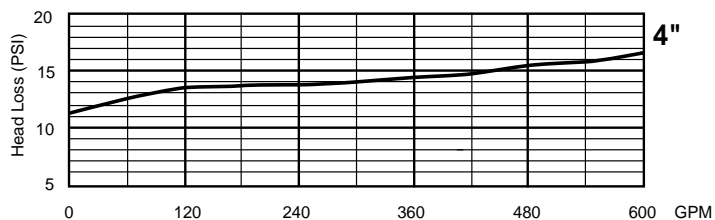
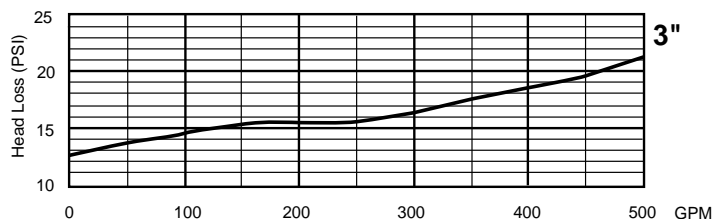
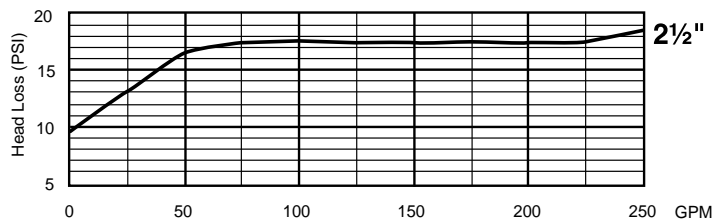

**Distributed by:**  
**Daniel L. Jerman Co.**  
275 Railroad Place  
Hackensack, NJ 07601

Phone 800.654.3733  
Fax 201.487.3953  
International Phone 201.487.7444