

# SPECIFICATION SHEET MODEL 825YA (3/4" - 2")

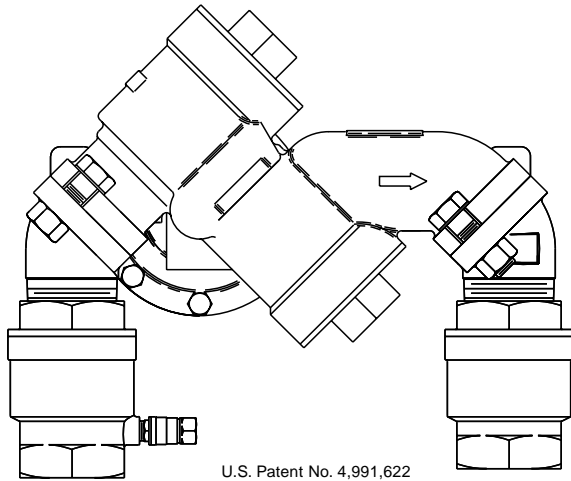

## Angle Pattern Reduced Pressure Assembly



### FEATURES

- Installation versatility simplifies new and retrofit installations.
- Eliminates pipe elbows, nipples and unions from the installation.
- Reduces installation time, labor costs and materials.
- Compact design simplifies retrofit.
- Integral flanged union connections allow assembly to be removed from the line for freeze protection or maintenance without the danger of spool substitution.
- Approved by the Foundation for Cross-Connection Control and Hydraulic Research at the University of Southern California.
- Modular relief valve and check valve internal components for ease of maintenance. Smaller, less costly protective enclosures can be used to provide freeze protection and vandalism protection due to compact size of valve.
- Field tested design for reliability and performance.
- Replaceable relief valve seat ring for longer valve life.
- Low head loss for optimum performance.

### OPERATION

In a flow condition, the check valves are open with the pressure between the checks, called the zone, being maintained at least 5 PSI lower than the inlet pressure. The relief valve is held closed by the pressure differential.

Should abnormal conditions arise under no flow or reversal of flow, the differential relief valve will open and discharge to maintain the zone at least 2 PSI lower than the supply.

When normal flow resumes, the zone's differential pressure will return and the relief valve will close.

### TYPICAL SPECIFICATION

The reduced pressure backflow preventer shall consist of two independently operating, spring loaded, "Y" pattern check valves and one hydraulically dependent differential relief valve. Should the differential between the upstream and the zone of the unit drop to 2 PSI, the differential relief valve shall open and maintain the proper differential.

Mainline valve body and caps including relief valve body and cover shall be bronze. Check valve moving members shall be center stem guided. Relief valve shall have a removable seat ring. Check valve and relief valve components shall be constructed so they may be serviced without removing the valve body from the line. All seat discs shall be reversible.

The assembly shall include flanged unions located between the mainline valve body and the ball valve shut-offs to allow for field removal for freeze protection or maintenance without danger of spool replacement.

The assembly shall be rated to 175 PSI water working pressure and water temperature range from 32°F to 140°F. The assembly shall meet the requirements of the USC Foundation of Cross Connection Control and Hydraulic Research, Eighth Edition.

The assembly shall be a FEBCO Model 825YA or prior approved equal.

### TYPICAL APPLICATIONS

Reduced Pressure assemblies are used to protect against toxic fluids in water services to industrial plants, hospitals, morgues, mortuaries, and chemical plants. They are also used in irrigation systems, boiler feed, water lines and other installations requiring the highest level of mechanical protection.

### AGENCY COMPLIANCE

- Approved by the Foundation for Cross-Connection Control and Hydraulic Research at the University of Southern California.
- ANSI/AWWA C511-89 Conformance
- ASSE Listed (Std 1013)
- CAN/CSA B64.4 Certified

## VERTICAL FLOW IN / VERTICAL FLOW OUT

### DIMENSIONS AND WEIGHTS\*

(U.S. - Inches)

Size	A	B	C	D	D1	E	F	G**	(Lbs.)
3/4"	10	8 1/2	3 1/4	4 7/8	4 5/8	4 1/8	3 1/2	1 5/8	15.0
1"	10 1/4	8 1/2	3 1/4	5 1/4	5	4 1/8	3 7/8	1 5/8	16.5
1 1/2"	14 3/4	11 1/2	4 1/2	6 7/8	6 1/2	5	4 5/8	2 5/8	38.0
2"	14 7/8	11 1/2	4 1/2	7 1/2	7 1/8	5	5 1/4	2 5/8	41.0

(Metric - MM)

Size	A	B	C	D	D1	E	F	G**	(Kgs.)
20	254.0	215.9	82.6	123.8	117.5	104.8	88.9	41.3	7.0
25	260.4	215.9	82.6	133.4	127.0	104.8	98.4	41.3	8.0
40	362.0	292.1	114.3	174.6	165.1	127.0	117.5	66.7	17.0
50	377.8	292.1	114.3	190.5	181.0	127.0	133.4	66.7	19.0

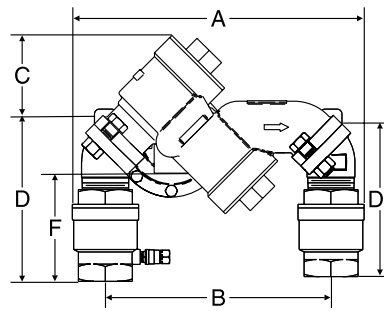

### DIMENSION LEGEND

- A Overall lay length, outside dimension
- B Centerline of inlet shutoff to centerline of outlet shutoff
- C Centerline of assembly to top
- D End of inlet shutoff to centerline of assembly
- D1 Centerline of assembly to end of outlet shutoff
- E Centerline of assembly to outside of relief valve
- F Bottom of relief port to end of inlet shutoff
- G Centerline of assembly to outside of flange

## VERTICAL FLOW IN / HORIZONTAL FLOW OUT

### DIMENSIONS AND WEIGHTS\*

(U.S. - Inches)

Size	A	B	C	D	D1	E	F	G**	(Lbs.)
3/4"	12 5/8	11 7/8	4 1/2	3 5/8	N/A	4 1/8	3 1/2	1 5/8	15.0
1"	13 1/3	12 1/4	4 1/2	4	N/A	4 1/8	3 7/8	1 5/8	16.5
1 1/2"	18	16 5/8	6	5 1/4	N/A	5	4 5/8	2 5/8	38.0
2"	19	17 1/4	6	5 7/8	N/A	5	5 1/4	2 5/8	41.0

(Metric - MM)

Size	A	B	C	D	D1	E	F	G**	(Kgs.)
20	320.7	301.6	114.3	92.1	N/A	104.8	88.9	41.3	7.0
25	338.7	311.2	114.3	101.6	N/A	104.8	98.4	41.3	8.0
40	457.2	422.3	152.4	133.4	N/A	127.0	117.5	66.7	17.0
50	482.6	438.2	152.4	149.2	N/A	127.0	133.4	66.7	19.0

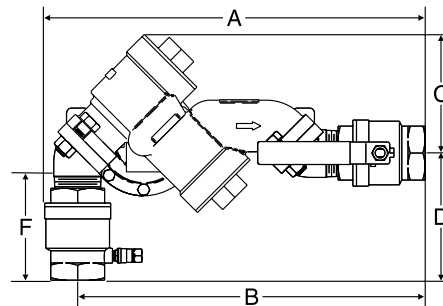

### DIMENSION LEGEND

- A Overall lay length, outside dimension
- B Centerline of inlet shutoff to centerline of outlet shutoff
- C Centerline of assembly to top
- D End of inlet shutoff to centerline of assembly
- E Centerline of assembly to outside of relief valve
- F Bottom of relief port to end of inlet shutoff
- G Centerline of assembly to outside of flange

## HORIZONTAL FLOW IN / VERTICAL FLOW OUT

### DIMENSIONS AND WEIGHTS\*

(U.S. - Inches)

Size	A	B	C	D	D1	E	F	G**	(Lbs.)
3/4"	12 7/8	12 1/8	4 1/2	3 5/8	N/A	4 1/8	3 1/4	1 5/8	15.0
1"	13 3/8	12 1/2	4 1/2	3 3/4	N/A	4 1/8	3 1/2	1 5/8	16.5
1 1/2"	18 3/8	17	6	4 7/8	N/A	5	4 1/4	2 5/8	38.0
2"	19 3/8	17 5/8	6	5 1/2	N/A	5	4 7/8	2 5/8	41.0

(Metric - MM)

Size	A	B	C	D	D1	E	F	G**	(Kgs.)
20	327.0	308.0	114.3	92.1	N/A	104.8	82.6	41.3	7.0
25	339.7	317.5	114.3	95.3	N/A	104.8	88.9	41.3	8.0
40	466.7	431.8	152.4	123.8	N/A	127.0	108.0	66.7	17.0
50	492.1	447.7	152.4	139.7	N/A	127.0	123.8	66.7	19.0

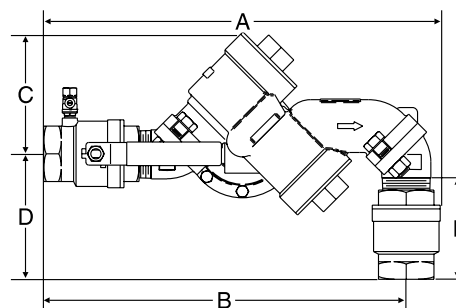

### DIMENSION LEGEND

- A Overall lay length, outside dimension
- B Centerline of inlet shutoff to centerline of outlet shutoff
- C Centerline of assembly to top
- D End of inlet shutoff to centerline of assembly
- E Centerline of assembly to outside of relief valve
- F Bottom of relief port to end of inlet shutoff
- G Centerline of assembly to outside of flange

# HORIZONTAL FLOW IN / HORIZONTAL FLOW OUT

## DIMENSIONS AND WEIGHTS\*

(U.S. - Inches)

Size	A	B	C	D	D1	E	F	G**	(Lbs.)
3/4"	15 1/2	N/A	4 1/2	N/A	N/A	4 1/8	N/A	1 5/8	15.0
1"	16 1/4	N/A	4 1/2	N/A	N/A	4 1/8	N/A	1 5/8	16.5
1 1/2"	22	N/A	6	N/A	N/A	5	N/A	2 5/8	38.0
2"	23 3/8	N/A	6	N/A	N/A	5	N/A	2 5/8	41.0

(Metric - MM)

Size	A	B	C	D	D1	E	F	G**	(Kgs.)
20	393.7	N/A	114.3	N/A	N/A	104.8	N/A	41.3	7.0
25	412.8	N/A	114.3	N/A <td N/A	104.8	N/A	41.3	8.0	
40	558.8	N/A	152.4	N/A	N/A	127.0	N/A	66.7	17.0
50	593.7	N/A	152.4	N/A	N/A	127.0	N/A	66.7	19.0

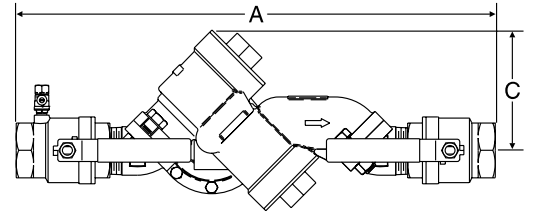

### DIMENSION LEGEND

- A Overall lay length, outside dimension
- C Centerline of assembly to top
- E Centerline of assembly to outside of relief valve
- G Centerline of assembly to outside of flange

## TOP VIEW

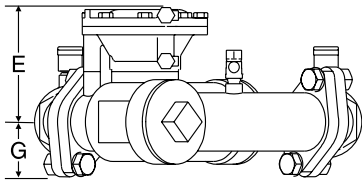

\* All dimensions are approximate. Allowances must be made for normal manufacturing tolerances.

\*\* Dimensions are based on standard vertical flow in / vertical flow out configuration.

## VERTICAL FLOW IN/VERTICAL FLOW OUT MODEL 825YA FLOW CURVES

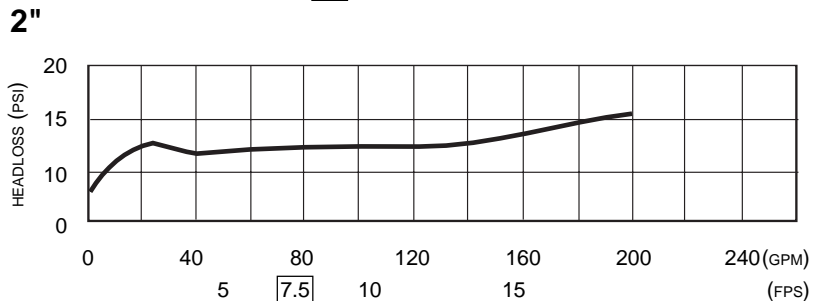
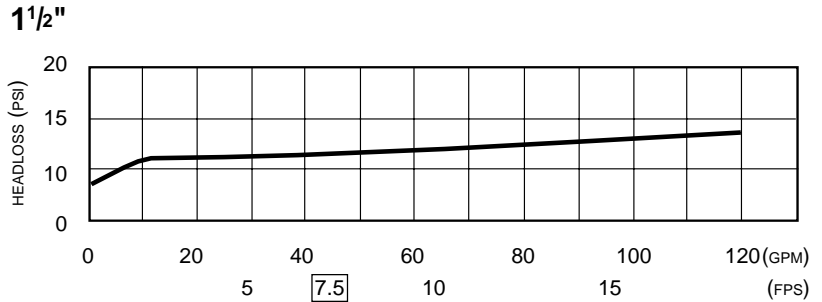
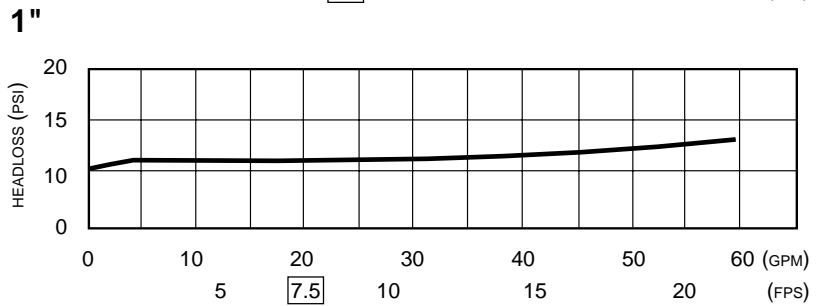
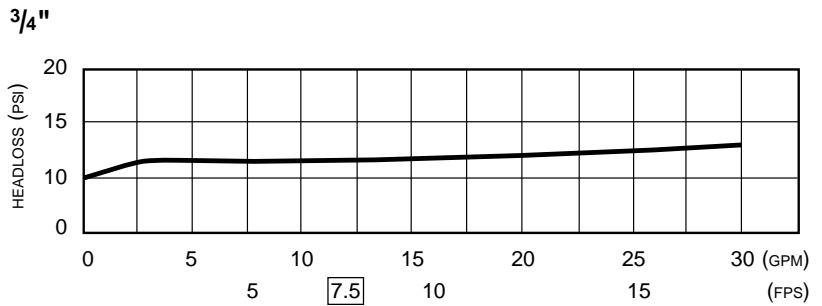

## INSTALLATION

The FEBCO Model 825YA provides versatility in installation because it can be installed in any of four configurations. The most typical configuration is shown in the vertical up flow in/vertical down flow out diagram. This provides for an extremely short lay length which is advantageous in areas of limited space for installation within a protected enclosure. Cost savings can be realized due to the reduction in materials needed such as nipples, elbows, unions, and size of the enclosure. With the integral flanged union connections the assembly can be removed from the line for freeze protection without a spool substitution. It is not recommended that any backflow prevention assembly be removed from the line for maintenance unless assurance can be made that a spool cross connection cannot be substituted. The flanged union connection mounted at 45 degrees will provide this assurance. The FEBCO Model 825YA is shipped in the configuration shown in the vertical up flow/vertical down flow out diagram, but can easily be modified to the three other configurations (shown on inside of this specification sheet) simply by removing the bolts to rotate the end adapters.

With any configuration, material and labor savings can be achieved. The FEBCO Model 825YA is the only Reduced Pressure Assembly which provides these options in a compact, integral assembly. All internal components are interchangeable with the FEBCO Model 825Y providing the same ease of maintenance and reliable operation.

Reduced Pressure Backflow preventers should be installed with a minimum clearance of 12" between port and floor or grade. They must be installed where discharge will not be objectionable and can be positively drained away. They should be installed where easily accessible for testing and maintenance and must be protected from freezing. Thermal water expansion and/or water hammer downstream of the backflow preventer can cause excessive pressure. Excessive pressure situations should be eliminated to avoid possible damage to the system and device.

## CHARACTERISTICS

Maximum working pressure	175 PSI (1200 KPa)
Hydrostatic test pressure	350 PSI (2400 KPa)
Temperature range	32°F to 140°F (0° to 60°)
Fluid	Water
End Detail	Threaded ANSI/ASME B1.20.1
Main valve body	Bronze
Relief valve body	Bronze
Elastomers	Seat Disc: Nitrile Diaphragms: Nitrile, fabric reinforced.
Springs	Stainless Steel

### TYPICAL INSTALLATION

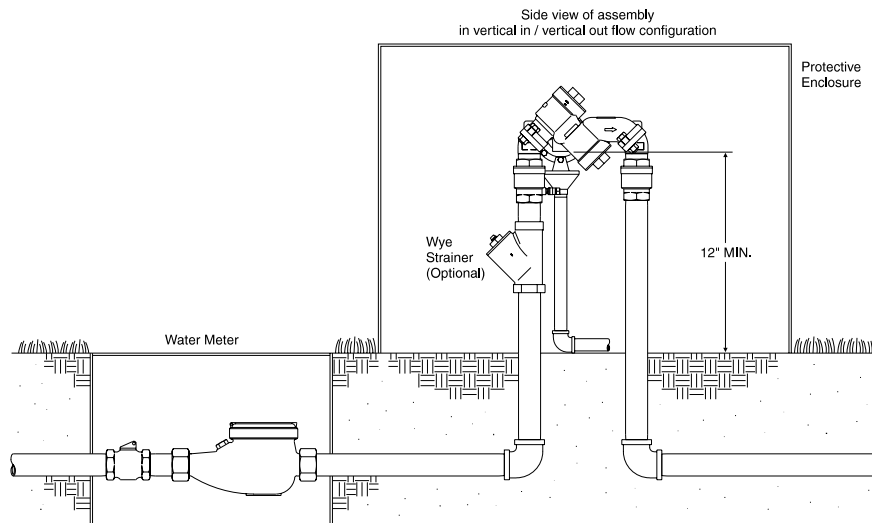

**Distributed by:**  
**Daniel L. Jerman Co.**  
275 Railroad Place  
Hackensack, NJ 07601

Phone 800.654.3733  
Fax 201.487.3953  
International Phone 201.487.7444

**FEBCO**  
BACKFLOW PREVENTION