

# SPECIFICATION SHEET MODEL 601



BACKFLOW PREVENTION

**Air Gap Drain Kit 2 1/2" - 10"**  
**For use with the MasterSeries reduced pressure assemblies**

## Air Gap Drain Kit

The model 601 Air Gap Drain Kit is constructed of coated aluminum. The air gap drain is designed to be attached to the relief valve of MasterSeries reduced pressure assemblies, sizes 2 1/2" through 10". Four inch drainage piping may be attached to drain, creating a system that catches and removes minor relief valve discharges due to pressure fluctuations and/or minor check valve fouling.

## Features

- Nozzle design directs flow directly into funnel, reducing side spray.
- Funnels minor relief valve discharges into drains.
- Lightweight for easy installation.
- Coated for corrosion resistance.
- 4" funnel outlet is designed to accept a hubless pipe coupling for simple drain pipe installation.

## Materials Specifications

| Part    | Material                                                                          |
|---------|-----------------------------------------------------------------------------------|
| Nozzle  | ASTM B26 Alloy 358                                                                |
| Funnel  | ASTM B26 Alloy 356                                                                |
| Rods    | ASTM B241 Alloy 6063                                                              |
| Coating | Pratt & Lambert, Inc. Vitralon polyurethane coating black # 88-1204 or equivalent |

## Dimensions

|         | Inches   | (mm)    |
|---------|----------|---------|
| A       | 13 1/8"  | (333.4) |
| B       | 6 3/8"   | (161.9) |
| C       | 5 3/8"   | (136.5) |
| D       | 3 1/2"   | (88.9)  |
| E       | 3 13/16" | (96.8)  |
| F       | 2 7/32"  | (56.4)  |
| G       | 4 3/8"   | (111.1) |
| H       | 9 7/8"   | (250.8) |
| Weight: | lbs      | (kg)    |
|         | 2.2      | (1.0)   |

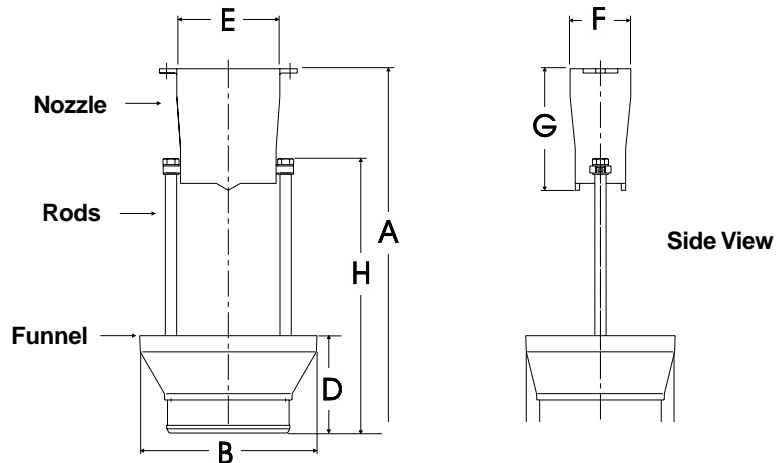

**Part Number: 905-213**

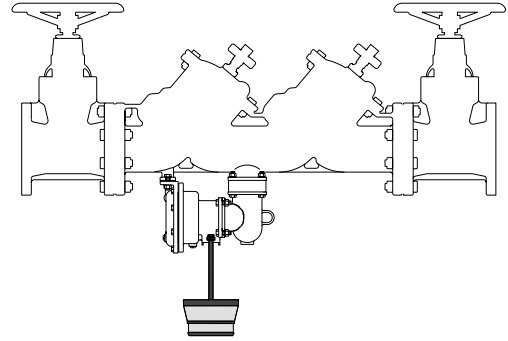

**Airgap Drain Side View Model 860**

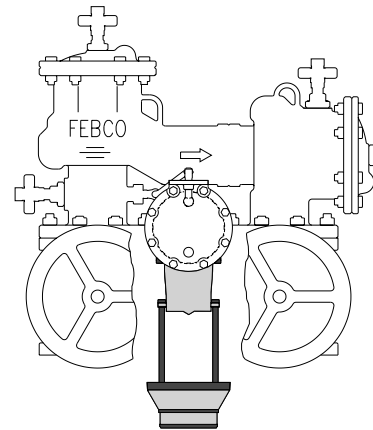

**Airgap Drain Front View Model 880**

**Distributed by:**  
**Daniel L. Jerman Co.**  
 275 Railroad Place  
 Hackensack, NJ 07601

Phone 800.654.3733  
 Fax 201.487.3953  
 International Phone 201.487.7444

