

**MAINTENANCE MANUAL INDEX  
REDUCED PRESSURE ASSEMBLY  
MODELS 860, 880 AND 880V (2 1/2" - 10")**

**VANDALISM**

**FEATURES AND OPERATING PROCEDURES**

**TROUBLE SHOOTING PROCEDURES AND GUIDE**

**GENERAL SERVICE PROCEDURES**

**SERVICE PROCEDURES FOR MODELS 860, 880 AND 880V (2 1/2" - 10")**

**TESTING**

**FREEZE PROTECTION PROCEDURES**

**CUT-A-WAY VIEW OF MODEL 860 (2 1/2"- 10") (FIGURE # 6)**

**CUT-A-WAY VIEW OF RELIEF VALVE (2 1/2"- 10") (FIGURE # 7)**

**CUT-A-WAY VIEW OF 10" DISC (FIGURE # 9)**

**CUT-A-WAY VIEW OF MODEL 880V (STANDARD CONFIGURATION) (FIGURE # 8)**

**PARTS LIST FOR MODELS 860, 880, AND 880V (2 1/2"- 10")**

**HOW TO ORDER PARTS**

**KIT NUMBERS FOR MODELS 860, 880, AND 880V (2 1/2"- 10")**

**WARRANTY**



# TABLE OF CONTENTS

DESCRIPTION	PAGE
Vandalism .....	2
Features and Operating Procedures .....	3
Trouble Shooting Procedures and Guide .....	4-5
General Service Procedures .....	6
Service Procedures for Models 860, 880 and 880V (2½" - 10") .....	6-8
Testing .....	9
Freeze Protection Procedures .....	9
Cut-a-way View of Model 860 (2½"- 10") (figure #6) .....	10
Cut-a-way View of Relief Valve (2½"- 10") (figure #7) .....	10
Exploded View of Relief Valve (2½"- 10") (figure #8) .....	10
Cut-a-way View of Model 880V (standard configuration) (figure #9) .....	11
Cut-a-way View of 10" Disc (figure #10) .....	11
Parts List for Models 860, 880, and 880V (2½"- 10") .....	12-13
How To Order Parts .....	14
Kit Numbers for Models 860, 880, and 880V (2½"- 10") .....	14-15
Warranty .....	Back Cover

## VANDALISM

If the unit is installed where vandalism may be a problem, the assembly should be protected and secured. A chain can be looped through both shut-off valve handwheels and locked in position to prevent tampering. Test cock valve handles can also be removed. On backflow prevention assemblies installed in conjunction with fire sprinkler systems, a tamper switch can be placed on the OS&Y shut-off valves that will trigger an alarm if an unauthorized closure should occur.

A protective enclosure can be installed over the unit to discourage vandals. If an enclosure is used, it should be installed so that adequate clearance is available for maintenance and testing.

Consult local codes before installing any type of protective enclosure.

# FEATURES AND OPERATING PROCEDURES

## REDUCED PRESSURE BACKFLOW PREVENTER

The FEBCO Reduced Pressure Backflow Preventer Assembly consists of two independently operating, spring loaded check valves with a pressure differential relief valve located between the two checks. The pressure drop across the first check valve is approximately 7.0 PSID with no flow. The relief valve consists of a hydraulically balanced diaphragm with the high pressure side hydraulically connected to the upstream side of the first check. The low pressure side is hydraulically connected to the reduced pressure zone, thus the relief valve remains closed during normal operation. The low pressure side of the diaphragm is spring loaded to force the relief valve open when the pressure drop across the first check (and across the diaphragm) reduces to approximately 3.0 PSID. A complete assembly includes two shut-off valves and four test cocks.

Example sectional views below show typical components and flow passages with corresponding pressure readings (no flow conditions) at the various locations within the assembly with 100 PSI line pressure.

**NOTE:** The 880V, when installed in the vertical orientation, must include vertical support under the second check body section. (See Figure #2.)

**MODEL 860 (2 1/2" - 10")**

FIGURE #1

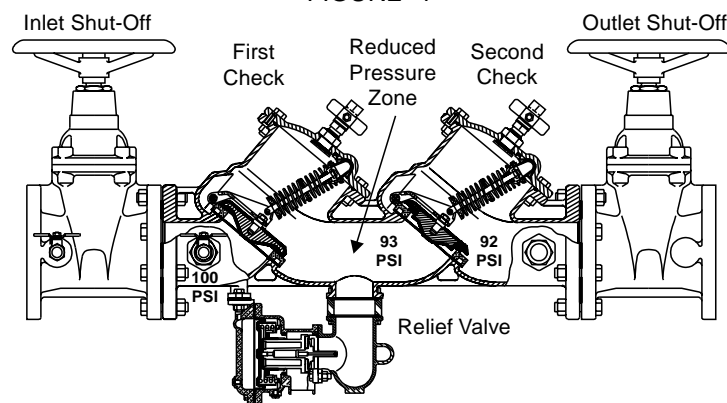

**MODEL 880V (2 1/2" - 10")**

FIGURE #2

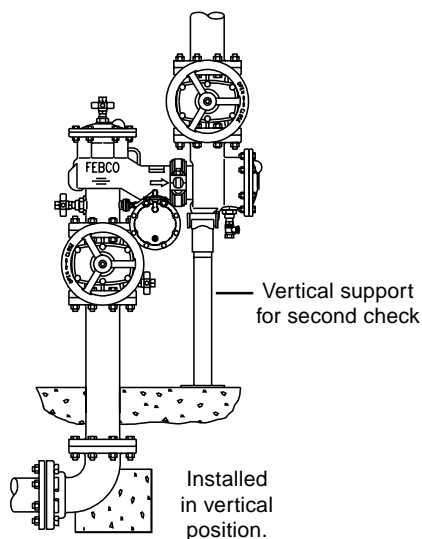

**MODEL 880V  
Standard Configuration (2 1/2" - 10")**

FIGURE #3

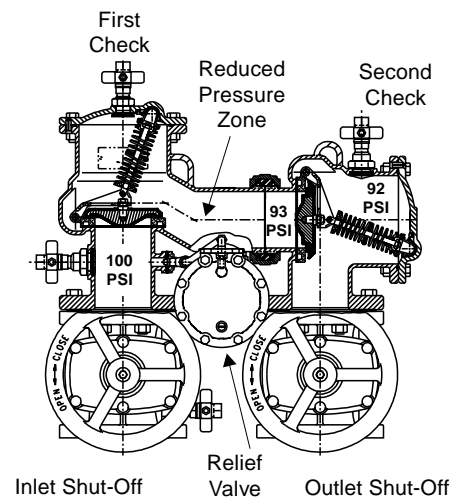

# TROUBLE SHOOTING GUIDE

## With Differential Pressure Gauge

Symptom #1:	Reading:	Problem:
Check Differential Across #1 Check Valve	2 to 3 PSID	Leak in #1 or #2 check valve
	6 to 8 PSID and steady	Malfunctioning pressure relief valve
	2 to 7 PSID and steady	Inlet pressure fluctuating
Symptom #2	Reading:	Problem:
Check Differential Across #1 Check Valve	2 to 3 PSID	#1 check valve held open
	6 to 8 PSID and steady	Malfunctioning pressure relief valve.

## Without Differential Pressure Gauge

Symptom #1 and #2:	Result:	Problem:
A) Close Gate Valve #2	If discharge stops	Leak in #2 check valve
	If discharge does not stop	Go to "B"
	Result:	Problem:
B) Open #4 test cock to produce a flow greater than differential relief valve discharge.	If discharge stops	Leak in #1 check valve
	If discharge does not stop	Malfunctioning pressure relief valve

Symptom #1:	Cause:	Solution:
<p>Continuous discharge from relief valve during NO FLOW conditions (Discharge stops with water flow).</p> <p>With this symptom, the pressure drop across the #1 check valve would be 2 to 3 PSID. If a flow of water (more than discharge) is created through the valve, the pressure drop should increase to approximately 7 PSI.</p>	A. Debris fouling #1 check valve.	Inspect and clean
	B. Outlet pressure higher than inlet pressure and debris fouling #2 check valve.	Inspect and Clean
	C. Spring stem not moving freely.	Inspect for dirt or other foreign material
	D. Damaged seat or seat disc.	Inspect and replace.
	E. Leakage at seal under the seat ring.	Inspect and replace seal.

Symptom #2	Cause:	Solution:
<p>Intermittent discharge from relief valve during NO FLOW conditions. With the symptom, the pressure drop across the #1 check valve would be varying from about 2 to 7 PSID.</p>	A. Inlet line pressure variations causing relief valve to discharge.	Eliminate or reduce pressure variations by installing a soft seated, spring loaded check on upstream side of device.
	B. Pressure surges (water hammer) causing relief valve to discharge as pressure wave passes through the zone.	Eliminate or reduce pressure surges

Symptom #3	Cause:	Solution:
<p>Continuous discharge from relief valve during FLOW and NO FLOW conditions.</p> <p>With this symptom, the pressure drop across the #1 check valve would be 7 PSID or more at all times.</p>	A. Seat disc dislodged from cavity in the main stem (this can be caused by pressure surges during initial filling of system lines)	Reposition disc in main stem cavity. Repressurize system slowly.
	B. Debris fouling the relief valve seat	Inspect and clean.
	C. Debris blocking the relief valve sensing passage	Inspect and clean.
	D. Dirt or scale jamming main stem	Inspect and clean, or replace.
	E. Leakage at main stem	Inspect and clean, or replace.

## TROUBLE SHOOTING GUIDE - CONTINUED

Symptom #4	Cause:	Solution
Relief valve does not open above 2.0 PSID during field testing.	A. Outlet gate valve not closed completely.	Check for debris blocking gate valve.
	B. Plugged low pressure hydraulic passage (from "ZONE" to inner diaphragm).	Inspect and clean.
	C. Improper alignment of internal parts during reassembly (causing high resistance to movement).	Reassemble.
	D. Jammed main stem due to debris.	Clean.

Symptom #5:	Cause:	Solution:
First check pressure drop is low (less than 5 PSID) during field testing.	A. Debris fouling first check seat.	Inspect and clean.
	B. Debris fouling second seat with backpressure.	Inspect and clean.
	C. Inlet pressure variations causing inaccurate gauge reading.	Eliminate pressure variations. (see symptom 2A).
	D. Disc does not move freely in arm. (Therefore, disc not parallel to seat ring).	Inspect and clean if required.
	E. Damaged seat or seat disk.	Inspect and replace as required.
	F. Worn guide, bushing or stem.	Inspect and replace as required.
	G. Bearing not properly seated in cover.	Inspect and reassemble.

Symptom #6	Cause:	Solution:
Second check fails to hold back pressure during field testing.	A. Outlet gate valve not closed completely.	Check for debris blocking gate valve.
	B. Debris fouling second check seat.	Inspect and clean.
	C. Disc not moving freely in assembly.	Inspect for dirt or other foreign material.
	D. Damaged seat or seat disk.	Inspect and replace if required.
	E. Worn guide, bushings or stem.	Inspect and replace if required.
	F. Bearing not properly seated in cover.	Inspect and reassemble.

Note: If check valve seat disc has been severely cut at the seat ring diameter, the assembly is being subjected to extremely high and repeated back pressure. Either thermal water expansion or water hammer are the most likely causes.

## GENERAL SERVICE PROCEDURES

1. FEBCO backflow prevention assemblies can be serviced with commonly available tools and are designed for ease of maintenance. The assemblies are designed to be serviced in line, so the unit should not need to be removed from the line during servicing. **NO special tools required.**
2. The most common cause of check fouling and relief valve discharge is dirt and debris in the seating areas. The line should be flushed clean of debris before installation of the assembly. To flush the line after installation of the assembly, slowly close the inlet shut-off valve, remove the covers and spring assemblies of both check valves and open the inlet shut-off valve to allow sufficient flow of water through the assembly to clear all sand, debris, etc. from the line. If debris in the water continues to cause fouling, a strainer may be installed upstream of the assembly. (Check local codes.)
3. Rinse all parts with clean water before reassembly.
4. Carefully inspect diaphragms, seals and seating surfaces for damage or debris. If the check valve seat disc has been severely cut at the seat ring diameter, the assembly has been subjected to extremely high and repeated back pressure. Either thermal water expansion or water hammer are the most likely causes. If back pressure persists, consider installation of a pressure relief valve downstream of the assembly.
5. Use caution to avoid damaging any guiding surfaces while handling parts. Do not force parts together. The o-ring seals used in FEBCO assemblies require only a small tightening force to insure a positive seal.
6. Test unit after servicing in accordance with the locally approved test method to insure proper operation.
7. Refer to applicable parts list and cut-a-ways (See pages 10-15 for visual aid information).
8. Use petroleum jelly (food grade).

## CHECK VALVE DISASSEMBLY

### SPRING MODULE REMOVAL (See pages 10-11)

1. Slowly close outlet shut-off valve and inlet shut-off valve. Bleed residual pressure by opening #4, #3, and #2 test cocks.
2. Remove cover bolts, removing the two bolts last that are located next to the retainer pin. Remove cover.

**NOTE:** Spring module is positioned in the body by the cover. Spring module is captured.

3. Remove pivot bearing (item 13) from the upper spring retainer of the spring module. Inspect pivot bearing (item 13) and bearing socket (item 15). Small hole in bearing socket indicates replacement is required. Remove retaining clip (item 5.1) from groove on one end of the load pin (item 7). Hold spring module with one hand while sliding out load pin (item 7) from arm (item 4). Lift out spring module and inspect for wear or damage. Replace spring module if necessary .

### CHECK DISK REMOVAL (See pages 10-11)

1. Remove jam nut (item 16) and washer (item 17) from check disc stem threads. Lift the arm and remove the check disc (item 6). Inspect sealing surface for debris or damage. Replace check disc if necessary.

**NOTE:** When jam nut (item 6) is tight, check disc is designed to “wobble.”

## SEAT RING ASSEMBLY REMOVAL (See pages 10-11)

**NOTE:** Remove the seat ring assembly only if the seat ring (item 3) or arm (item 4) appear to be worn or damaged.

1. Remove locknuts (item 3.4) and washers (item 3.3). (See Figure #4 below.)
2. Remove seat ring assembly.

**NOTE:** When reassembling, tighten locknuts to 12 - 15 ft./lbs. If leaking occurs around bolt, further tighten until leaking stops. Do not over tighten.

3. Remove retaining clip (item 5) from one end of the swing pin (item 4.2). Hold arm (item 4) while sliding out swing pin (item 4.2). Inspect bushings (item 4.1) and pin (item 4.2) for wear or damage. Replace if necessary. Inspect gasket (item 3.1) for debris and/or damage. Replace if necessary.

**NOTE:** Reverse the procedure above, to reassemble the components. Seat ring will only fit into body one way. Check alignment of seat ring if studs don't align with body holes. Gasket is also non-symmetric. Both seat ring and gasket have a notch that indicates non-symmetric hold. Clean all parts thoroughly with clean water before reassembly. Reassemble and bleed test cocks #4, and #3. Repressurize the assembly and test assembly in accordance with the locally approved test method.

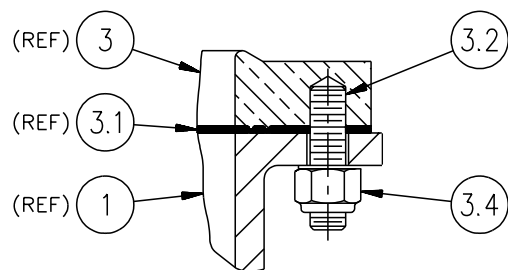

**SEAT RING**  
FIGURE #4

## RELIEF VALVE REMOVAL

(See pages 10-11)

1. Remove capscrews (item 24), washers (item 24.1) and nuts (item 25) at base of relief valve body and hydraulic sensing port. Remove relief valve seat ring (item 34) from bottom of relief valve. Inspect seat ring (item 34), seat disc (item 32), and guide (item 33) for debris, wear, or damage. Replace as necessary. (See below.)

## RELIEF VALVE SEAT DISC REPLACEMENT

(See pages 10-11)

1. Separate relief valve from elbow and sensing line flange. Remove cover bolts (item 22) and cover (item 20).
2. Lift out diaphragm (item 37) and inspect for damage. Replace if necessary.
3. Grasp spring button (item 28) and pull out relief valve module.
4. Turn over relief valve assembly module so that guide (item 33) stem is facing up. Use tabs on guide (item 33) to loosen guide. Unscrew guide and replace seat disc (item 32).
5. **Reassemble in reverse order.**

## RELIEF VALVE DISASSEMBLY (See pages 10-11)

1. Remove o-ring (item 34.1) and RV seat ring (item 34) from the bottom of RV body.
2. Remove RV cover (item 20) from RV body by removing eight capscrews (item 22).
3. Remove diaphragm from RV body. Remove RV assembly module from RV body (item 21).
4. Loosen tabs on guide (item 33) and remove guide and seat disc (item 32), remove instruction label (item 28.2) from center of button, covering flow screw (item 28.1).
5. Loosen flow screw (item 28.1) **CAUTION spring is captured.** Remove spring (item 29) from main guide (item 31), remove flow washer (item 30) from top of diaphragm (item 37).
6. Remove stem (item 30) and stem washer (item 30.1), on end of stem, from diaphragm guide assembly.
7. Unscrew retainer from main guide (item 31) and remove slip ring (item 38.1) from retainer.
8. Remove small diaphragm (item 37) from main guide (item 31).

## RELIEF VALVE ASSEMBLY (See pages 10-11)

**NOTE:** Clean all parts thoroughly with clean water before reassembly.

1. Place small diaphragm (item 37) into main guide (item 31) with beaded side of flange pointed down.
2. Drop slip ring (item 38.1) into retainer (item 38) and screw retainer into main guide (item 31) as shown, being careful not to bind the diaphragm's cup shape with your finger.
3. Place stem washer (item 30.1) on end of stem (item 30) and insert stem into diaphragm guide assembly. When the stem is fully inserted it does not bottom out against diaphragm, so do the following: Press diaphragm against stem with your thumb and forefinger and slowly pull the stem back out with the diaphragm. Place stem guide assembly on bench with diaphragm pointed up.
4. Place flow washer (item 39) on top of diaphragm (item 37) with slots facing up and with holes lining up. Set spring (item 29) on main guide (item 31) and compress spring with button (item 28). With spring fully compressed insert and tighten down flow screw (item 28.1), being careful not to twist button or assembly which will distort the diaphragm.
5. Stick instruction label (item 28.2) in center of button, covering flow screw (item 28.1). Install seat disc (item 32) into stem (item 30) and install guide (item 33) to retain disc. Using tabs on guide, tighten until shoulder on guide contacts stem.
6. Lubricate o-ring (item 31.1) with petroleum jelly (food grade) and install on main guide (item 31).
7. Install assembly into relief valve body (item 21). Place large diaphragm (item 27), with cap facing down, into RV body and fold over stem assembly button. Pull diaphragm flange up onto RV body flange.
8. Assemble RV cover (item 20) to RV body using eight capscrews (item 22) and tighten to 120 inch-pound torque wrench limit.
9. Insert RV seat ring (item 34) into bottom of RV body (aligning it with guide (item 33)) and install o-ring (item 34.1).

**N-SHAPE (V) ONLY** - Assemble complete relief valve assembly to valve body as shown with o-ring (item 35) and back-up ring (item 35.1), using four capscrews (item 24), eight washers (item 24.1) and four nuts (item 25). Tighten to 120 inch-pounds torque wrench limit. Attach sensing line flange cover (item 36). **Do not over tighten.**

**IN-LINE ONLY** - Assemble completed unit to valve body and elbow with gasket (item 26) install with screen facing valve body) using six capscrews (item 24), twelve washers (item 24.1) and six nuts (item 25). Tighten to 120 inch-pounds torque wrench limit. **Do not over tighten.**



## TESTING

All mechanical devices should be inspected on a regular basis to ensure they are working correctly. The assembly should be tested at time of initial installation, after servicing or maintenance, and at least annually thereafter. Acceptable test procedures are published by Foundation for Cross Connection Control and Hydraulic Research at the University of Southern California (USC), The American Water Works Association (AWWA), The American Society of Sanitary Engineering (ASSE Series 5000) and the Canadian Standards Association (CAN/CSA B64•10). Please consult the regulatory authority in your area for more specific information.

---

## FREEZE PROTECTION

The Reduced Pressure Backflow Prevention Assembly may be subject to damage if the internal water is allowed to freeze. It is suggested that all assemblies be installed with resilient seated shut-offs so that a drip tight closure can be achieved to prevent refilling of the assembly after the freeze protection procedure is performed. The unit must be protected from freezing using a heated enclosure, insulation using heat tape, or other suitable means. If the system will be shut down during freezing weather, use the following procedure to drain internal passages. A system should have a shut off valve located upstream of freeze protection area, and a means for draining upstream of the #1 shut off and downstream of the #2 shut-off valve.

## REDUCED PRESSURE ZONE AND RELIEF VALVE

For more detailed instructions on freeze protection procedures request "Freeze Protection Instructions for RP Devices."

1. Slowly close supply valve upstream of freeze protected area, open all test cocks on the backflow preventer. All water within the zone will be drained to the lowest point of the relief valve discharge port (relief valve seat). A small amount of water will remain in the bottom of the main valve body, but this is not sufficient to cause freeze damage. Leave test cocks and ball valves in half open, half closed position for the winter.
2. All water on the inlet side, and within the zone, will be drained down to the #1 test cock on the Model 880 and 880V. All water will be drained from the inlet side and the zone of the Model 860.
3. For sizes 2 $\frac{1}{2}$ " - 10", remove both drain plugs from bottom of relief valve assembly. Replace when draining is complete.
4. Drain upstream of the #1 shut-off valve and downstream of the #2 shut-off valve.
5. Proceed to step 6 Ball Valve Shut Off Draining Procedure.

## BALL VALVE SHUT-OFF DRAINING PROCEDURE

6. If the assembly has been installed with ball valve shut-off valves, they must also be properly drained to prevent freeze damage. After the draining procedure has been completed on the backflow prevention assembly, position all ball valve shut-offs and test cocks in a half open/half closed (45 degree) position. (see Figure #5)
7. Open the ball valve approximately 45 degrees, while draining the pipeline and assembly, to allow water between the ball valve and valve body to drain. Leave the ball valve in this position for the winter to prevent freeze damage.
8. The ball valves must be fully closed before the system is repressurized. **OPEN AND CLOSE BALL VALVES SLOWLY TO PREVENT DAMAGE TO THE SYSTEM CAUSED BY WATER HAMMER.**

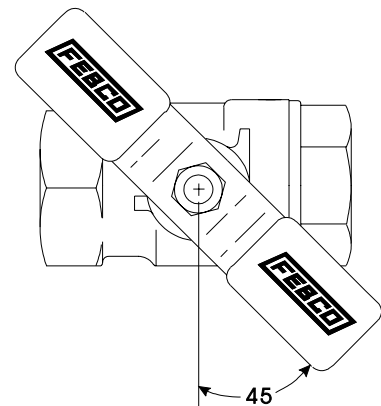

**BALL VALVE (2 $\frac{1}{2}$ " - 2")**

Figure #5

**MODEL 860 CUT-A-WAY**

FIGURE #6

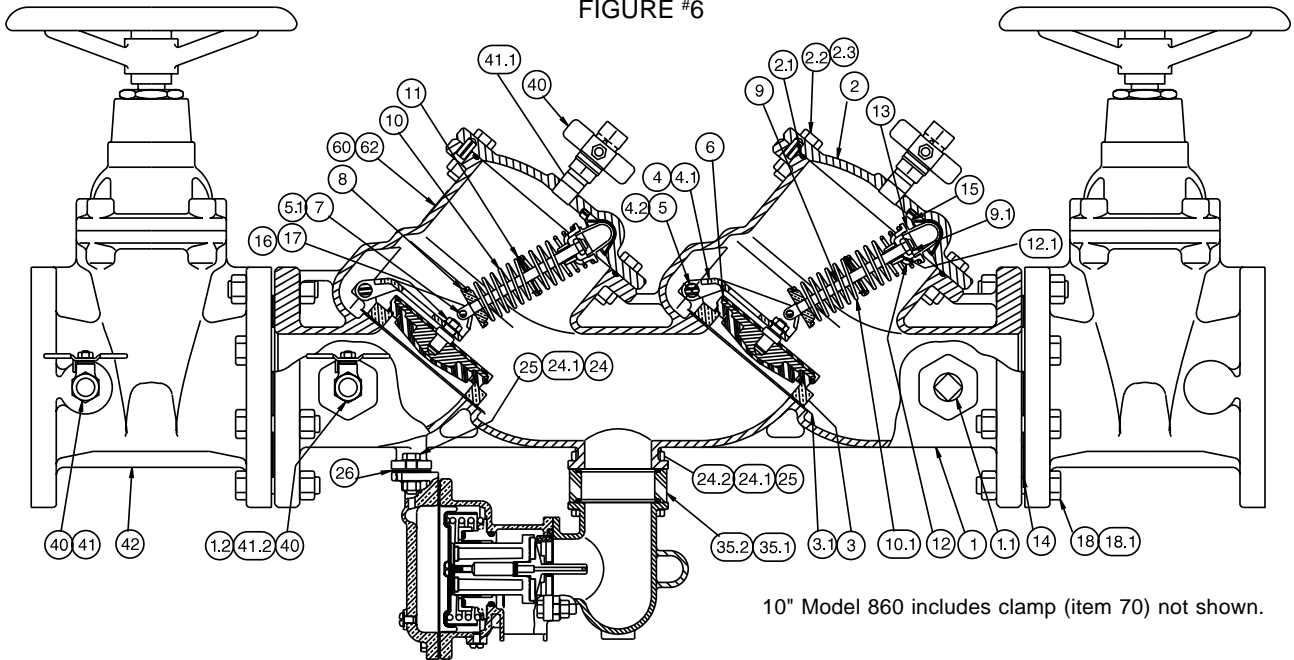

10" Model 860 includes clamp (item 70) not shown.

**RELIEF VALVE CUT-A-WAY**

(2 1/2" - 10")

FIGURE #7

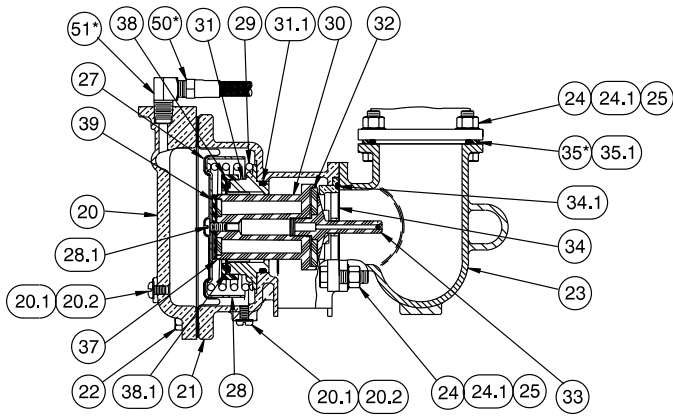

\* Model 880, 880V only.

**RELIEF VALVE EXPLODED**

(2 1/2" - 10")

FIGURE #8

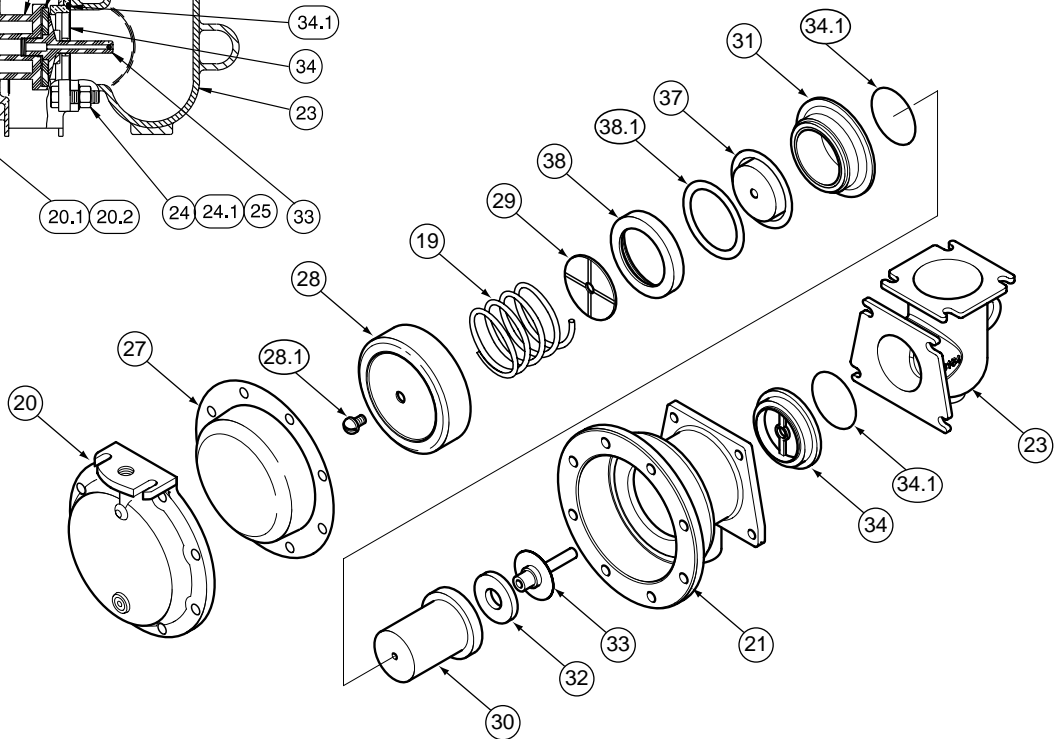



## MODEL 860 / 880 / 880V (2 1/2" - 10") PARTS LIST

Item	Description	Qty.	2 1/2"	3"	4"	6"	8"	10"
1	Body (860)	1	880-131	880-132	880-133	880-134	880-135	N/A
	Body (880/880V)	1	880-193	880-194	880-188	880-189	880-190	880-191
1.1	Pipe Plug (860)	1	578-171-50	578-171-50	578-171-50	578-171-50	578-171-50	N/A
1.2	Bushing	1	571-161-54	571-161-54	571-161-54	571-161-54	571-161-54	
2	Cover (860)	2	880-250	880-250	880-251	880-252	880-253	N/A
	Cover 1 <sup>st</sup> Check(880/880V)	1	880-192	880-192	880-175	880-176	880-177	880-178
2.1	O-Ring	2	39625579	39625579	396-261-79	396-269-79	396-276-79	396-279-79
2.2	Capscrew	16	51101614	51101614	511-017-14	511-019-18	511-020-18	511-020-20
2.3	Hex Nut	16	52101600	52101600	521-017-00	521-101-90	521-020-00	521-020-00
2.4	Expansion Pin	2	360-089	360-089	360-089	360-089	360-089	360-089
2.5	Cover 2 <sup>nd</sup> Check (880/880V)	1	880-106	880-106	880-107	880-108	880-109	880-110
3	Seat Ring	2	110-071	110-071	110-072	101-259	101-260	101-261
3.1	Gasket	2	450-102	450-102	450-106	450-108	450-109	450-110
3.2	Socket Head Screw	8	517-514-10	517-514-10	517-514-10	517-514-10	517-514-10	517-514-12
3.4	Elastic Stop Nut	8	523-514-00	523-514-00	523-514-00	523-514-00	523-514-00	523-514-00
4	Arm	2	101-212	101-212	101-207	101-208	101-210	101-211
4.1	Bushing Swing Pin	4	500-338	500-338	500-338	500-388	500-338	500-337
4.2	Swing Pin	2	240-137	240-137	240-137	240-138	240-139	240-140
5	Retaining Clip	4	740-118	740-118	740-118	740-118	740-118	740-119
5.1	Hairpin Cotter	4	740-120	740-120	740-120	740-120	740-120	740-120
6	Check Disk (860)	2	402-014	402-014	402-006	402-007	402-008	N/A
	Check Disk (880/880V)	2	402-030	402-030	402-031	402-032	402-008	N/A
	Seat Disk (10"- 880/880V)	2	N/A	N/A	N/A	N/A	N/A	400-145
6.1	Disk Holder (10" - 880/880V)	2	N/A	N/A	N/A	N/A	N/A	190-029
6.2	Disk Retainer (10"-880/880V)	2	N/A	N/A	N/A	N/A	N/A	190-034
6.3	Capscrew (10"-880/880V)	6	N/A	N/A	N/A	N/A	N/A	511-515-05
7	Load Pin	2	240-130	240-130	240-130	240-131	240-131	240-132
8	Lwr Spring Retainer	2	101-203	101-203	101-203	101-204	101-204	101-205
9	Spring Stem	2	240-116	240-116	240-117	240-118	240-119	240-120
9.1	Elastic Stop Jam Nut	2	720-054	720-054	720-054	720-055	720-055	720-055
10	Spring 1 <sup>st</sup> Check	2	630-154	630-154	630-155	630-156	630-157	630-158
10.1	Spring 2 <sup>nd</sup> Check	2	630-162	630-162	630-163	630-151	630-164	630-165
10.2	Spring Shim 2 <sup>nd</sup> Check (8")	1	N/A	N/A	N/A	N/A	500-354	N/A
11	Spring Guide	2	360-086	360-086	360-086	360-087	360-087	101-217
12	Upr Spring Retnr	2	101-216	101-216	101-216	101-206	101-206	101-221
12.1	Bushing-Spr. Stem	2	500-344	500-344	500-344	500-345	500-345	500-340
13	Pivot Bearing	2	101-218	101-218	101-218	101-219	101-219	101-220
14	Flange Gasket	2	780-365	780-366	780-367	780-368	780-369	780-370
15	Bearing Socket	2	500-335	500-335	500-335	500-336	500-336	500-336
16	Hex Jam Nut	2	524-515-00	524-515-00	524-515-00	524-517-00	524-517-00	511-517-06
17	Washer	2	360096	360-096	360-096	360-097	360-097	360-097
18	Flange Bolt	( )	(8)511-019-22	(8)511-019-22	(12)511-019-22	(12)511-019-22	(12)511-019-22	(24)511-019-22
18.1	Flange Nut	( )	(8)511-019-22	(8)511-019-22	(20)511-019-22	(20)511-019-22	(20)511-019-22	(24)511-019-22
18.2	Flange Stud	4	N/A	N/A	513-019-26	513-019-26	513-019-26	N/A
20	R.V. Cover	1	110-112	110-112	110-112	110-112	110-112	110-112
20.1	Bleed Screw	2	519-513-03	519-513-03	519-513-03	519-513-03	519-513-03	519-513-03

## MODEL 860 / 880 / 880V (2 1/2" - 10") PARTS LIST (CONTINUED)

Item	Description	Qty.	2 1/2"	3"	4"	6"	8"	10"
20.2	Gasket	2	340-078	340-078	340-078	340-078	340-078	340-078
21	R.V. Body	1	110-011	110-011	110-011	110-011	110-011	110-011
22	Cover Bolt	8	511-515-08	511-515-08	511-515-08	511-515-08	511-515-08	511-515-08
23	Elbow	1	880-154	880-154	880-154	880-154	880-154	880-154
24	RV Mtg Bolt	4	511-014-10	511-014-10	511-014-10	511-014-10	511-014-10	511-014-10
24.1	Washer - RV	4	360-090	360-090	360-090	360-090	360-090	360-090
24.2	Cap Screw	4	511-014-18	511-014-18	511-014-18	511-014-18	511-014-18	N/A
25	Nut	4	521-014-00	521-014-00	521-014-00	521-014-00	521-014-00	521-014-00
26	Gasket/Strainer	1	450-107	450-107	450-107	450-107	450-107	450-107
27	Lrg. Diaphragm	1	400-108	400-108	400-108	400-108	400-108	400-108
28	Button	1	300-118	300-118	300-118	300-118	300-118	300-118
28.1	Flow Screw	1	240-136	240-136	240-136	240-136	240-136	240-136
29	RV Spring	1	630-168	630-168	630-168	630-168	630-168	630-168
30	Stem - RV	1	500-399	500-399	500-399	500-399	500-399	500-399
31	Main Guide - RV	1	110-013	110-013	110-013	110-013	110-013	110-013
31.1	O-Ring - RV	1	396-230-79	396-230-79	396-230-79	396-230-79	396-230-79	396-230-79
32	Seat Disc - RV	1	400-123	400-123	400-123	400-123	400-123	400-123
33	Lower Guide	1	500-342	500-342	500-342	500-342	500-342	500-342
34	Seat Ring	1	110-015	110-015	110-015	110-015	110-015	110-015
34.1	O-Ring	1	396-229-79	396-229-79	396-229-79	396-229-79	396-229-79	396-229-79
35	O-Ring	2	396-233-79	396-233-79	396-233-79	396-233-79	396-233-79	396-233-79
35.1	Back-Up Ring	1	500-350	500-350	500-350	500-350	500-350	500-350
35.2	Extension	1	500-388	500-388	500-388	500-388	500-388	500-388
36	Adaptor Plate (880/880V)	1	101-252	101-252	101-252	101-252	101-252	101-252
37	Sm. Diaphragm	1	400-109	400-109	400-109	400-109	400-109	400-109
38	Retainer	1	110-014	110-014	110-014	110-014	110-014	110-014
38.1	Slip Ring	1	340-103	340-103	340-103	340-103	340-103	340-103
39	Flow Washer	1	500-387	500-387	500-387	500-387	500-387	500-387
40	Ball Valve	4	781-047	781-047	781-047	781-048	781-048	781-048
41	Nipple	1	571-181-45	571-181-45	781-181-45	571-181-53	571-181-56	571-181-56
41.1	Nipple (860)	2	571-181-43	571-181-43	571-181-43	571-181-53	571-181-53	N/A
41.2	Nipple (860)	1	571-181-44	571-181-44	571-181-44	571-181-55	571-181-55	N/A
42	Gate Valve (NRS)	2	781-005	781-006	781-007	781-008	781-009	781-010
	Gate Valve (OSY)	2	780-891	780-893	781-895	780-897	780-899	780-901
43	Bulkhead Fitting (880/880V)	2	110-003	110-003	110-003	101-249	101-249	101-249
43.1	Bulkhead Fitting (880/880V)	1	101-237	101-237	101-237	101-249	101-249	101-249
45	Gasket (880/880V)	2	450-105	450-105	450-105	450-105	450-105	450-105
45.1	Gasket (880/880V)	1	450-104	450-104	450-104	450-105	450-105	450-105
47	Nut (880/880V)	2	101-251	101-251	101-251	101-251	101-251	101-251
47.1	Nut (880/880V)	1	101-250	101-250	101-250	N/A	N/A	N/A
50	Sensing Line (880/880V)	1	781-159	781-159	781-159	781-159	781-159	781-159
51	Street Elbow (880/880V)	2	200-830	200830	200-830	200-830	200-830	200-830
60	Identification Plate	1	380-113	380-113	380-113	380-113	380-113	380-113
62	Drive Screw	1	781-224	781-224	781-244	781-224	781-224	781-224
70	Clamp	1	781-179	781-179	781-180	781-181	781-182	781-183

Some of the above items are only available as part of a repair kit. Note: Bulkhead fittings are not furnished on the Model 860.  
Item 70 used on 880V (2 1/2"-10") and 860 (10") only.

## REPAIR KITS

### How to order parts and repair kits.

1. Locate item number and kit number in this maintenance manual.
2. Verify the size of the valve the parts are to be used on.
3. Provide full model number located on I.D. plate.
4. Give kit number.
5. A serial number (located on the I.D. plate) will assist in ordering the proper kits.
6. Contact your local FEBCO Parts Distributor.

### REPAIR KITS: MODEL 860 / 880 / 880V (2 1/2" - 10")

Kit Description	2 1/2"	3"	4"	6"	8"	10"
<b>Check Replacement Kit</b>						
Items	860 (inlet)	905-543	905-543	905-546	905-550	905-554 905-554
2.1, 3, 3.1, 3.2, 3.4, 4, 4.1, 4.2,	860 (outlet)	905-527	905-527	905-547	905-551	905-555 905-555
13, 15, 16, 17	880(V) (inlet)	905-544	905-544	905-548	905-552	905-554 905-556
	880(V) (outlet)	905-545	905-545	905-549	905-553	905-555 905-557
<b>860/880 RP Inlet Spring Module</b>						
Items						905-174(860)
2.1, 5.1, 7, 8, 9, 9.1, 10, 11, 12, 12.1	905-172	905-172	905-173	905-174	905-175	905-176 (880)
<b>860/880 RP Outlet Spring Module</b>						
Items						905-145(860)
2.1, 5.1, 7, 8, 9, 9.1, 10.1, 10.2*, 11, 12, 12.1	905-142	905-142	905-143	905-144	905-145	905-146(880)
<b>860 Disc Assembly</b>						
Items						
2.1, 6, 16, 17	905-182	905-182	905-183	905-184	905-185	905-185
<b>880 (V) Disc Assembly</b>						
Items						
6, 16, 17 - (10" - item 6 only)	905-224	905-224	905-225	905-226	905-185	400-145
<b>Seat Ring / Arm Assembly</b>						
Items						905-160(860)
3, 3.1, 3.2, 3.3, 3.4, 4, 4.1, 4.2, 5	905-157	905-157	905-158	905-159	905-160	905-161(880)
<b>860 Rubber Parts Kit (Checks and RV)</b>						
Items						
2.1, 3.1, 6, 15, 16, 17, 26, 27, 31.1, 32, 34.1, 35.1, 35.2, 45, 45.1	905-187	905-187	905-188	905-189	905-190	905-190
<b>880 (V) Rubber Kit (Checks and RV)</b>						
Items						
2.1, 3.1, 6, 15, 16, 17, 26, 27, 31.1, 32, 34.1, 35, 35.1, 37, 45, 45.1	905-227	905-227	905-228	905-229	905-190	905-191
<b>Relief Valve Repair Kit</b>						
Items						
26, 27, 28, 29, 30, 31.1, 31.2, 32, 33, 34, 34.1, 37	905-192	905-192	905-192	905-192	905-192	905-192

\*8" only

Kit Description (Cont.)	2½"	3"	4"	6"	8"	10"
<b>Relief Valve Internal Assembly Kit</b>						
Items						
27, 28, 28.1, 29, 30, 31, 31.1, 32, 33, 37, 38, 38.1, 39	905-320	905-320	905-320	905-320	905-320	905-320
<b>860 Cover Assembly Both Checks</b>						
<b>880 (V) Inlet Check Only</b>						
Items						905-170(860)
2, 2.1, 15	905-167	905-167	905-168	905-169	905-170	905-171(880)
<b>880 (V) Cover Assembly Outlet Check Only</b>						
Items						
2.1, 2.5, 15	905-244	905-244	905-245	905-246	905-247	905-248
<b>Bulkhead Fittings Assembly Cover</b>						
Items						
43.1, 45.1, 46.1, 47.1	905-275	905-275	905-275	-	-	-
<b>Bulkhead Fittings Assembly Body</b>						
Items						
43, 45, 46, 47	905-276	905-276	905-276	-	-	-
<b>Bulkhead Fittings Assembly Body and Cover</b>						
Items						
43, 45, 46, 47	-	-	-	905-277	905-277	905-277
<b>Bulkhead Plug Assembly 2nd Check Cover (N &amp; V Units) Early Prod.</b>						
Items						
44, 45.1, 46.1, 47.1	905-278	905-278	905-278	-	-	-
<b>Bulkhead Plug Assembly 2nd Check Cover (N &amp; V Units) Early Prod.</b>						
Items						
44, 45, 46, 47	-	-	-	905-279	905-279	905-279
<b>860 Relief Valve Assembly</b>						
Items						
24, 24.1, 24.2, 25, 35.1, 35.2, 201	905-294	905-294	905-294	905-294	905-294	905-294
<b>880 (V) Relief Valve Assembly</b>						
Items						
24, 24.1, 25, 26, 35.1, 36, 50, 51, 201	905-295	905-295	905-295	905-295	905-295	905-295
<b>860 Check Rubber Kit</b>						
Items						
2.1, 3.1, 6, 15, 16, 17, 26, 35.1, 35.2, 45, 45.1	905-409	905-409	905-410	905-411	905-412	905-412
<b>880(V) Check Rubber Kit</b>						
Items						
2.1, 3.1, 6, 15, 16, 17, 26, 35, 35.1, 45, 45.1	905-413	905-413	905-414	905-415	905-412	905-416
<b>860 / 880 (V) Relief Valve Rubber Kit</b>						
Items						
26, 27, 31.1, 32, 34.1, 37	905-316	905-316	905-316	905-316	905-316	905-316

Some of the above items are only available as part of a repair kit.

Note: Bulkhead fittings are not furnished on the Model 860.

## WARRANTY

All products manufactured and sold by CMB Industries, Inc. carry with them the following warranty: CMB Industries, Inc. warrants to the original purchaser (who is the end user) all products manufactured by it will be free from defects in workmanship and material for a period of one (1) year from the date of original shipment.

CMB Industries, Inc. also warrants that all internal components of 1/2" through 2" Model 850/860 and 1/2" through 1" Model 766 products, will be free from defects in workmanship and material for a period of five (5) years from the date of original shipment and also that the body only of the 1/2" through 1 1/4" Model 765 will be subject to a lifetime warranty against damage by freezing.

This warranty is applicable provided such products are used under normal conditions within the recognized pressure, flow and temperature limits and are given normal service and care. CMB INDUSTRIES, INC. MAKES NO OTHER REPRESENTATION OR WARRANTY OF ANY KIND, EXPRESSED OR IMPLIED, IN FACT OR IN LAW, AND EXPRESSLY DISCLAIMS ALL OTHER WARRANTIES, INCLUDING WITHOUT LIMITATION, THE WARRANTIES OF MERCHANTABILITY OR FITNESS FOR PARTICULAR PURPOSE. In the event of a defect in material or workmanship of a product covered by this warranty, CMB Industries, Inc. shall, at its sole option, repair or replace such defective product. CMB Industries, Inc. shall not be liable for any labor required to repair or replace any product covered by this warranty. This warranty is void with respect to any such product which is altered or tampered with by anyone without prior consent of CMB Industries, Inc. CMB Industries, Inc. shall not be liable under any circumstances for damages caused by accident, misuse or abuse of the product or for failure to follow the installation, maintenance or operating instructions. IN NO EVENT SHALL CMB INDUSTRIES BE LIABLE FOR CONSEQUENTIAL, INCIDENTAL, INDIRECT, PERSONAL INJURY, PROPERTY OR PUNITIVE DAMAGES.

To make a claim under this warranty, the buyer must notify the factory in writing within ten (10) days of discovery of any claimed defects or workmanship, and if authorized by the factory, shall return the product in the same condition as when received by the buyer, transportation prepaid, to the factory or to such other location as directed by the factory. If said returned product is found by the factory to be defective in workmanship or materials, it shall be repaired or replaced without charge, pursuant to the terms of this warranty. This warranty excludes component parts or appurtenances not manufactured by CMB Industries, Inc. Any claims with respect to such equipment must be made to the manufacturer thereof in accordance with the terms of the warranty, if any, given by such manufacturer, or pursuant to such warranties as may exist by law. The physical or chemical properties of CMB Industries, Inc. products represent typical, average values obtained in accordance with test methods and are subject to normal manufacturing variations. This information is supplied as a technical service and is subject to change without notice.

## FEBCO BACKFLOW PREVENTION...

**A product of CMB Industries, Inc.**

CMB Industries Inc. is a leader in the water control market with more than 75 years of experience in the design and manufacturing of the world's most innovative water control products. CMB Industries products include the FEBCO Backflow Prevention Assemblies, The POLYJET Control Valve, and K-FLO Butterfly Valve.

For more information on how FEBCO Backflow Prevention or other CMB Industries products can meet your specific installation or project need, contact the factory or an authorized representative today.

**Distributed by:**  
**Daniel L. Jerman Co.**  
275 Railroad Place  
Hackensack, NJ 07601

Phone 800.654.3733  
Fax 201.487.3953  
International Phone 201.487.7444

