

Specification Sheet

Industrial Compound Meters Model C3000 Cast Iron or Bronze, Magnetic Drive, Round Flanged Ends



Description

Operation. The C3000 Compound Meter is designed for installations where large variations in flow rate can be expected. These flow ranges are measured by utilizing the low flow capability of a positive displacement meter and the higher flow efficiency of a Class II turbine meter. The small meter is a standard C700. The measuring element of the large meter is a standard T3000 turbine meter. Located on the downstream side of the turbine measuring chamber, a changeover valve operates on differential pressure. Before the valve opens, all flow is directed through the C700 bypass meter. After the valve opens, flow goes through both measuring chambers.

Compliance to Standards. The C3000 compound meter fully complies with the American Water Works Association Standard C702 as most recently revised.

Installation. The meter must be installed in a clean pipeline, free from any foreign materials. Install the meter with direction of flow as indicated by the arrow cast in the meter case. The meter may be installed in horizontal or inclined lines. The AWWA M6 manual recommends 10 pipe diameters upstream and 5 pipe diameters downstream of straight pipe for optimal accuracy of all inferential type flowmeters. It is recommended that a plate strainer be used to protect the measuring elements and help reduce the effects of turbulence. Optional bypass trim valves are available to facilitate in-line bypass meter replacement while under pressure.

Application. The meter is for use with POTABLE COLD WATER up to 120°F (50°C) and working pressures up to 150 psi. The meter will perform with accuracy registration of 100% ± 1 1/2% within its normal flows of 5-3000 GPM. Both pressure loss and accuracy tests are made before shipment. No adjustments are necessary before installation.

Size 8"

Specifications

<u>Size</u>	8"
97%-101% Accuracy GPM	1 1/2
98.5%-101.5% Accuracy GPM	5-3000
Continuous Flow GPM	1875
Maximum Flow GPM	3000
Operating Pressure psi	150
Operating Temperature °F	120

<u>Sweep Hand Registers</u>	<u>Turbine</u>	<u>Bypass</u>
US Gallons	1000	100
Cubic Feet	100	10
Cubic Meters	10	1/10
Imperial Gallons	1000	10

<u>Capacity of Registers</u>	<u>Turbine</u>	<u>Bypass</u>
US Gallons (millions)	1000	100
Cubic Feet (millions)	100	10
Cubic Meters (millions)	10	1/10
Imperial Gallons (millions)	1000	10

<u>Register Type</u>	Permanently sealed direct reading registers.
----------------------	--

Materials

Main Case	Cast Iron or Bronze
Top Cover Plate	Bronze
Case Nuts and Bolts	Stainless Steel
Measuring Element	Polyphenylene Oxide
Rotor	Polypropylene
Rotor Bushings	PTFE Compound
Rotor Thrust Bearing	Ceramic Jewel
Rotor Spindle	Tungsten Carbide
Undergearing	Polyacetal Resin
Valve Main Case	Cast Iron
Changeover Valve	Polymer, Bronze, Stainless Steel & Rubber
Bypass Meter	Bronze
Measuring Chamber	Compounded Polymer
Register Lens	Tempered Glass
Register Housing & Lid	Polymer or Bronze
Register Can	90% Copper Alloy
Body O-Rings	Rubber & Nitrile

Construction. The meter consists of a main case, turbine measuring element, changeover valve, main case cover, oscillating piston bypass meter and magnetically driven register assemblies, bypass piping and bypass non-return valve. The main case is cast iron or bronze and the bypass meter is bronze. Each has raised characters showing model, size and direction of flow. The main case has a throated inlet. A case dowel pin is inserted for locating the bronze cover plate. The measuring element assembly consists of the rotor, straightening vanes, accuracy regulator, spindles and gears, filters and undergear assembly. The measuring element is attached to the underside of the main cover with four stainless steel screws and washers, one insert of which is placed eccentrically in the cover. The internal regulator assembly is interconnected with a shaft located on top of the cover and secured with a seal plug. The main case and cover are assembled with an O-ring gasket and stainless steel nuts, bolts and washers. The changeover valve is encased in a separate housing bolted to the downstream turbine flange. Its outlet flange is adjustable by 1 3/8". There is a check valve installed for the bypass meter. The bypass consists of 1 1/2" piping, elbows, couplings and a C700 1 1/2" oval flanged meter. A non-return valve installed in the meter's bypass arm, downstream of the bypass meter, prevents back-flow from the high flow chamber being registered on the bypass meter. The register assemblies are secured with tamperproof screws and are protected by hinged lids bearing the same serial number.

Register. Each register is contained within a 90% copper seamless can which is oven-cured at 150°F for 90 minutes to eliminate condensation. The 1/4" true tempered glass lens is domed and secured



with an "L" shaped gasket, then roll sealed. To assure easy reading, the totalizer wheels are large and color coded. The applicable size, model, registration, part number and date code are printed on the calibrated dial face. Moving clockwise during operation, extra thin sweep hands do not interfere with meter reading, and the low-flow indicator will detect plumbing leaks.

Connections. This meter has 8-bolt round flanged end connections. Both bronze and cast iron companion flanges are available. The companion flanges are faced, drilled and tapped with ANSI B2.1 internal taper pipe thread.

Maintenance. The measuring element with integral straightening vanes can be removed, repaired or replaced without removing the main case from the service line. Blank cover plates are available for the utility's use. Pretested and calibrated turbine measuring elements with cover plates and registers are available for exchange or purchase. The bypass meter may be repaired with standard C700 parts available from our warehouses in the U.S. and Canada. In addition, AMCO Water maintains a fully equipped and staffed repair facility in Ocala, Florida.

Pulser. See Specification Sheet #LRP/HRP-T3000 for Main Meter:

LRP (2 wire) Reed Switch, 4 watt (50 VAC/DC max.).
HRP (3 wire) Slotted Disc, 6-15 VDC.

See Specification Sheet #C7-PUL-001 for Bypass Meter:

"BI" Pulser (2 wire) Limit Switch (3 amps at 126 VAC max.).
"SFI" Pulser (3 wire) Solid State Device, 6-24 VDC.

Note: All pulsers require power from an external source.

Dimensions and Net Weight

Meter Size	A*	B	Dimensions (inches)				Weight (lbs.)
			C	D	E	F	
8" Iron	34 1/2	16	6 7/8	20 1/2	13 7/8	20 1/2	285
8" Bronze	34	16	6 7/8	20 1/2	13 7/8	20	227

*Length is adjustable by 1 3/8" from 33 1/8" minimum to 34 1/2" maximum for cast iron and 32 5/8" minimum to 34" maximum for bronze.

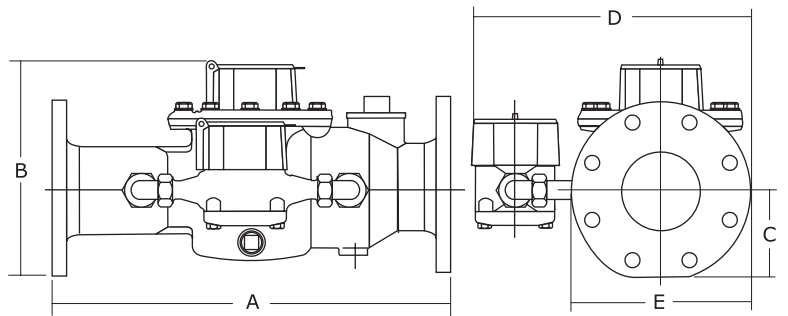

AMCO 
Distributed by:

www.watermeters.com

Daniel L. Jerman Co.
275 Railroad Place
Hackensack, NJ 07601
Phone 800.654.3733
Fax 201.487.3953
International Phone
201.487.7444