

- **Integrated water measurement system**
 - ❑ Combines flow, pressure and data logging in a single unit
 - ❑ Built-in multi-speed, multi-channel, dual-variable logger
 - High precision, high resolution data logging
 - ❑ Pressure sensor input
 - Enables monitoring and logging of line pressure
 - ❑ Bi-directional as standard
 - Equally accurate for forward and reverse flows
 - ❑ Flash programming technology
 - Supports local or remote via radio upgrade to product firmware
 - ❑ Supports improved customer service
 - User information for cost management

- **Improves revenue versus traditional mechanical meters**
 - ❑ Provides broad flow range, highest accuracy
 - ❑ Retains accuracy
 - No moving parts to wear and lose accuracy
 - ❑ Flow-profile conditioning sensor
 - Tolerant of poor upstream and downstream conditions
 - ❑ Bi-directional as standard
 - Equally accurate for forward and reverse flows

- **Offers lowest installation cost**
 - ❑ Compact & lightweight option to fire service and compound mechanical designs
 - Minimal personnel & equipment required for installation
 - Smaller size allows installation where mechanical meters are cost-prohibited
 - ❑ Submersible sensor & electronic display unit
 - Including flooded pits
 - ❑ Buriable sensor
 - Eliminates vaults
 - ❑ No strainer required
 - High accuracy unaffected by debris or turbulence
 - ❑ Battery powered option
 - Facilitates installation in remote locations
 - No external power supply required

- **Reduces operating/maintenance cost**
 - ❑ No moving parts to wear and lose accuracy
 - ❑ No strainer clean-out or valve maintenance
 - ❑ 3-year battery life (28 months on 14" or larger meters)
 - ❑ AC power not required
 - ❑ Lowers inventory cost

- **Flexibility**
 - ❑ Tariff function
 - Programmable for daily, weekly and seasonal rates
 - ❑ Logger database systems
 - Compatible with Technolog™ (PMAC), Primayer™ (Primeware), OSI™ PI database, IBV™ (WADIS) and LogMaster



AquaMaster S
- the next generation integrated
measurement system for water
system management

The Next Generation

Commercial Water Flow-Meter

AquaMaster™S is the next stage in the evolution of the groundbreaking AquaMaster family of flow meters from AMCO. An integrated water measurement system with outstanding performance combining flow, pressure measurement and datalogging in a single unit.

AquaMaster S eliminates system interconnection and configuration issues and ensures reliable start up with reduced overall user costs and improved data resolution for superior water system management.

AquaMaster S is the world's first flowmeter with field upgradeable firmware. This gives the user full 'future-proofing' as it permits future software enhancements to be downloaded to an installed AquaMaster S.

AquaMaster S, available in sizes 5/8" to 24" (15 to 600mm) has been designed specifically for the water industry in response to its stringent demands for enhanced metering capability enabling ever more efficient and cost-effective operation, improved customer service, and compliance with increasing legal requirements.

No External Power Required for Remote Locations

- No external power supply required (2 internal batteries).
- 3-year battery life (28 months on 14" or larger meters).
- Site-replaceable batteries.
- Unique battery management system gives a battery replacement window in excess of 1 year, with no flat battery interruption to measurement.

AquaMaster is the ideal solution for locations where there is no external power. Through new design technology, replaceable internal batteries provide a 3-year battery life, thus eliminating the high cost of providing a power supply to the meter.

Typical Applications

- Production metering
- Bulk revenue
- Treated effluent
- Custody transfer



Logger Facility

The AquaMaster S display unit also contains a multi-channel, multi-variable logger. The ability of the logger to run at two speeds simultaneously enables the user to investigate, in precise detail, the flow and pressure activity during a period of interest. This logger logs both flow and pressure (with optional pressure transducer) via a direct digital transfer of data, thereby ensuring optimum accuracy and resolution of measurement. Graph 1 (below) illustrates actual measurements showing extra detail captured utilizing the twin loggers. Traditional techniques of counting pulses over a short logging interval leads to 'quantization' effects corresponding to whole numbers of pulses on logger graphs which is shown on Graph 2 (below). AquaMaster S eliminates such effects, averaging digitally over the selected logging interval. Such high resolution data facilitates step testing, leak detection and water system analysis.

The AquaMaster's internal loggers feature an advanced automatic time synchronization feature which ensures operation on synchronized time boundaries, no matter what logging interval is set. This ensures all flow and pressure (with optional pressure transducer) data, when combined with data from other meters, is precisely synchronized, facilitating precise system balance.

For revenue application, not only is the flow and pressure logged information available, but included is a totalizer and tariff logger, which logs all volume totals (forward, reverse, net) and tariff reading totals every midnight. Its memory of 366 days keeps all records for one year. The readings stored are the precise register volumes and are not inferred by intergration of pulses or other similar techniques.

Security is incorporated where access to the loggers and modifying the configuration of logger setup is protected by user resettable passwords.

Graph 1:

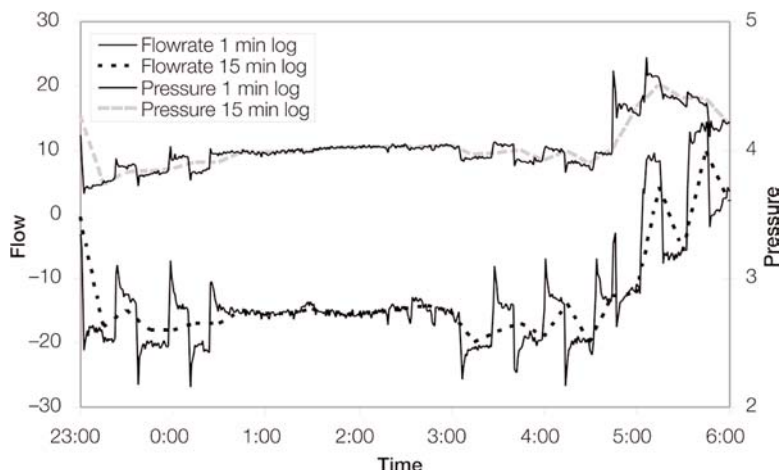

Graph 2:

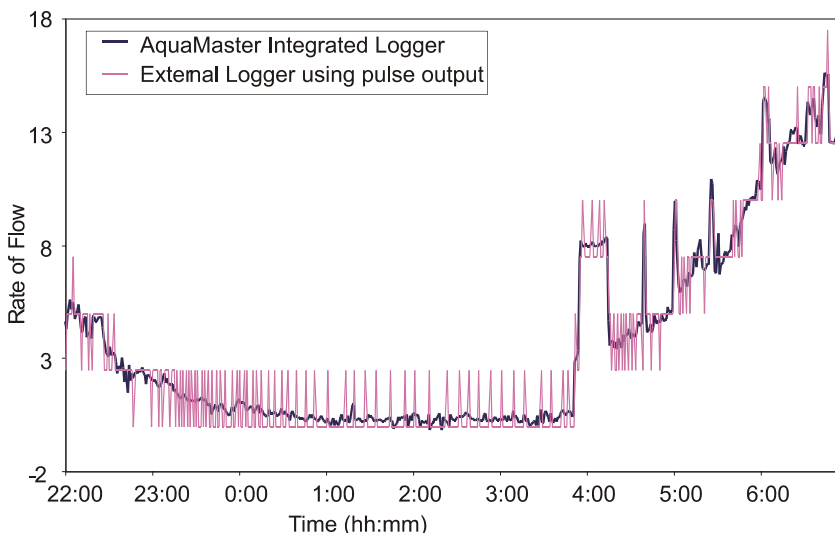

Support Software

AquaMaster S is available with a variety of industry standard third party software, Technolog™ [PMAC], Primayer™ [Primeware], OSI™ PI database and IBV™ [WADIS], for downloading, managing, analysis and display of data, either directly from the RS232 port or via telemetry. Separate specification sheets are available describing these systems.

AMCO also supplies LogMaster, a simple-to-use PC software program which provides local communication to the AquaMaster S. It enables full control and downloading of the on-board datalogger. A file-save facility enables data to be exported in CSV format for charting in Microsoft™ Excel or similar spreadsheets. LogMaster is Windows™ 98 & NT compatible, available in a variety of different languages.

Electronic Display Unit

- Comprehensive display
- Submersible for use in flooded pits rated IP68 (NEMA 6)
- Resettable or secure totals
- 1/5" high displays for totals (exceeds AWWA register digit requirements)
- Total security:
 - Two user-security levels
 - Anti-tamper switch and seals
- Three outputs (forward & reverse pulse, or pulses & direction and alarm)

The AquaMaster™ Electronic Display Unit provides the most comprehensive range of flow data and information currently available to the water industry. If all the data is not required, the unit can be configured so that only the required values are displayed, thus ensuring simple reading with no superfluous data. Likewise, the display is available for top or side viewing, depending on the location of the meter, for easy reading in all locations.

The AquaMaster's program memory or firmware uses reprogrammable Flash memory technology which has been enhanced to allow this firmware to be upgraded in the field, via a local serial port connection or a radio link, if fitted. This future-proofs AquaMaster, making enhancements or new features available to installed units.

The enclosure is provided in an IP68 rated metal version designed for integral or remote mounting where possible submersion can occur.

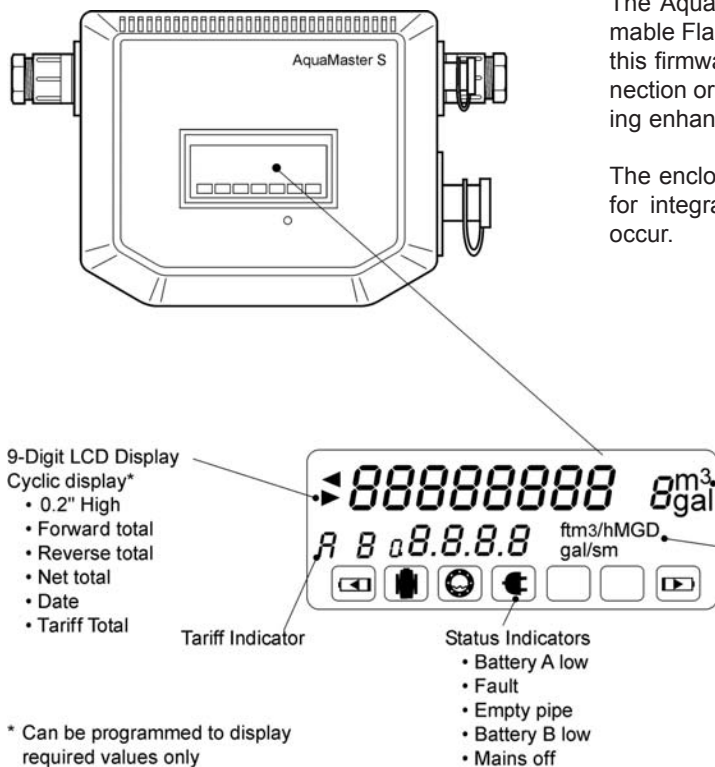

Standard Tariff Setting

AquaMaster S incorporates a multiple tariff feature where the accumulated flow volume is routed to one of two 8-digit signed tariffs; tariff A and tariff B, depending on time and date. It is fully programmable by the user for time of day, day of week or date during the year. These user-defined times/dates can be combined in a variety of modes as illustrated in the accompanying tables.

Weekly Cycle Defined

Mode	Tariff A	Tariff B
1	Day time during weekend	Night time at weekend + day and night during week
2	Day time during week	Night time during week + day and night during weekend
3	All day times	All night times
4	Night time during weekend	Day time during weekend + day and night during week
5	Day and night during weekend	Day and night during week
6	Day time during weekend + night time during weekend	Night time during week + day time during weekend
7	All day times + night time during weekend	Night time during week

Yearly Cycle Defined

Mode	Tariff A	Tariff B
1	Day time during summer	Night time during summer + day and night during winter
2	Day time during winter	Night time during winter + day and night during summer
3	All day times	All night times
4	Night time during summer	Day time during summer + day and night during winter
5	Day and night during summer	Day and night during winter
6	Day time during winter + night time during summer	Night time during winter + day time during summer
7	All day times + night time during summer	Night time during winter

Easy, Low Cost Installation

No matter what the location or installation requirements, AquaMaster™ provides a cost-effective solution.

Both the sensor and the Electronic Display Unit are fully submersible, enabling installation in flooded meter vaults.

In addition, the sensor is buriable, thus eliminating the expense of a vault. Installation merely involves excavating to the pipeline, fitting the sensor and back filling the hole, to ensure very fast, low cost installation. The associated Electronic Display Unit is then located in the most convenient position for the user, up to 650 feet from the sensor.

For new installations, the elimination of ancillary items (such as strainers) reduce material and installation cost. AquaMaster's compact size allows easy replacement of compound or turbine meters with the addition of spool pieces.

These factors, together with the innovative 'Fit and Flow™' system, ensure foolproof installation with total user confidence.

'Fit and Flow™'

- No need to match sensor and Electronic Display Unit
- Fast, reliable installation
- Foolproof, no errors
- Sensor stores all calibration factors, site settings numbers etc.
- Volume totalizer and tariff values backed-up every 5 minutes in sensor for total security
- Multiple, programmable password levels stored for measurement security
- Tamper resistant

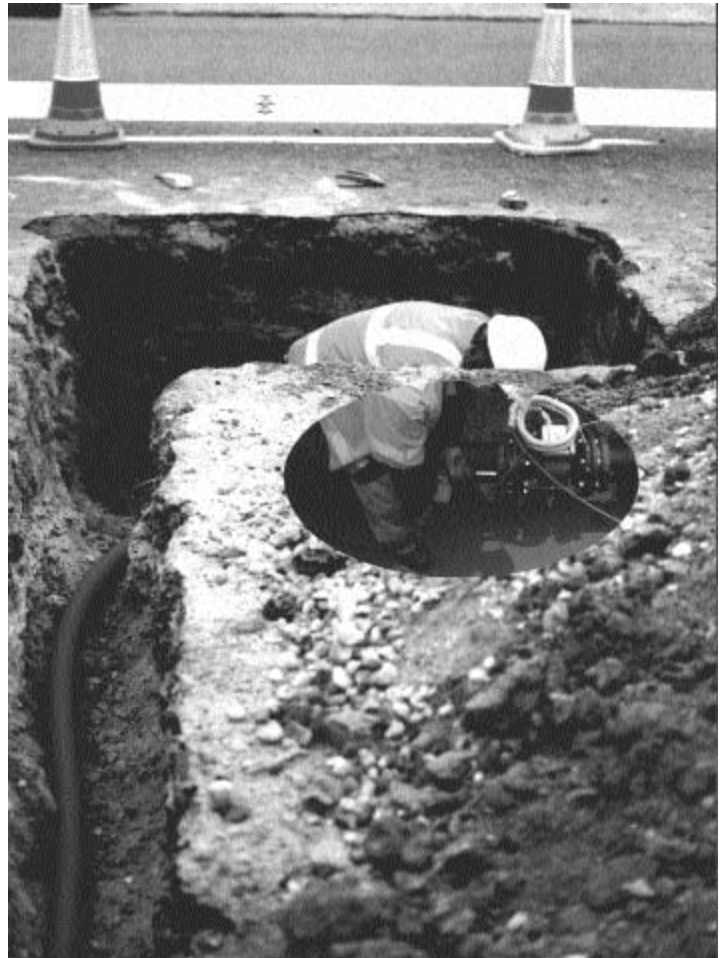

Underground Installation of AquaMaster™

New Performance Standards

Calibration Characteristics for AquaMaster S

The broadest flow range, optimum accuracy and long-term stable calibration means that AquaMaster sets new performance standards in the water industry.

Using the 4" AquaMaster as an example, the charts below illustrate AquaMaster's performance versus new mechanical meters. Compared to AWWA 701 Class II Turbine Meters, AquaMaster measures significantly lower flows while more accurately measuring the entire turbine flow range.

AquaMaster's high accuracy over a broad flow range also offers a revenue advantage over AWWA C702 Compound Meters. As illustrated for the 4" size, in addition to great accuracy at low flows and $\pm 0.5\%$ (AC $\pm 0.25\%$) for normal and high flows, AquaMaster avoids the accuracy loss that occurs at crossover in Fire Service and Compound Meters.

The clear bore of the AquaMaster eliminates the possibility of damage by particulate matter and the absence of moving and wearing components ensures that this unique level of performance is maintained long term.

The unique design of the AquaMaster sensor conditions the flow profile in the measuring section so that distortions in the flow profile, either upstream or downstream, are flattened, resulting in excellent in situ meter performance, even with poor hydraulic installation conditions.

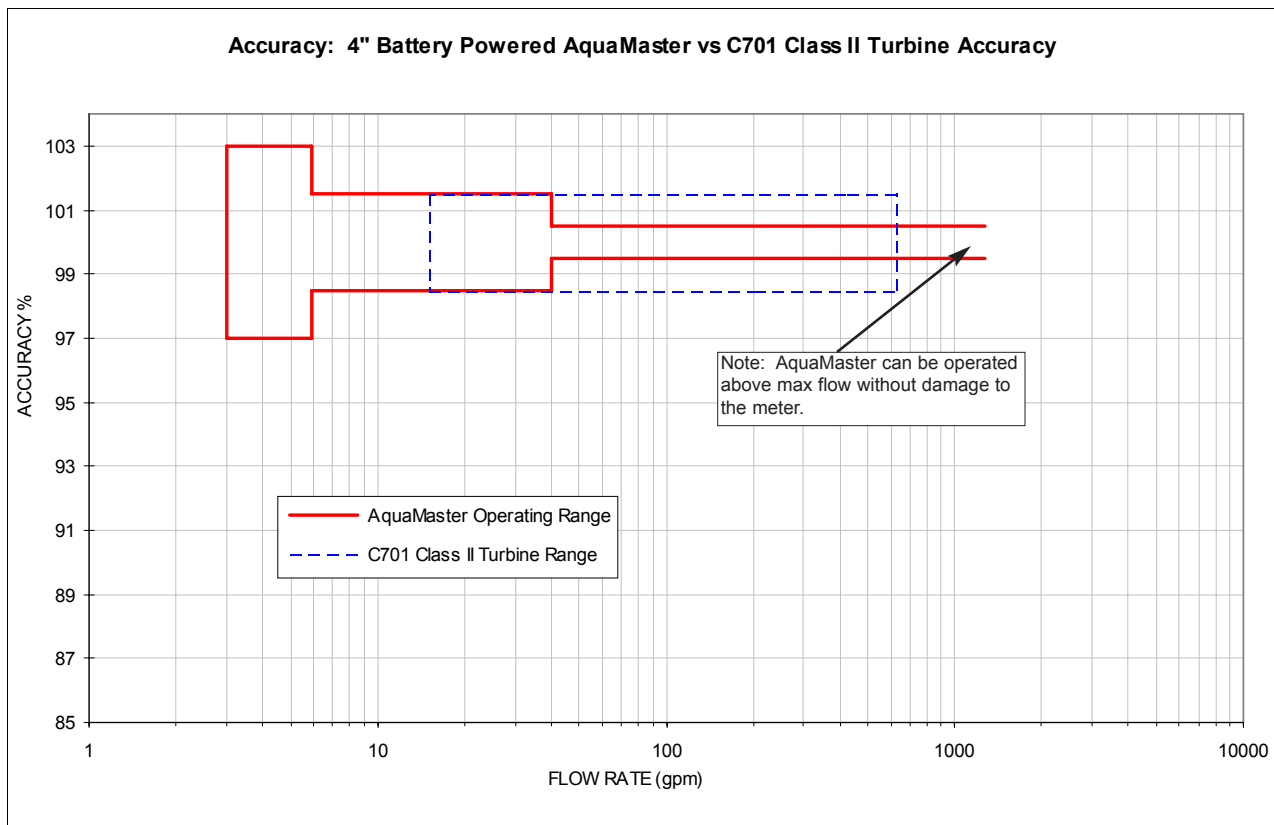

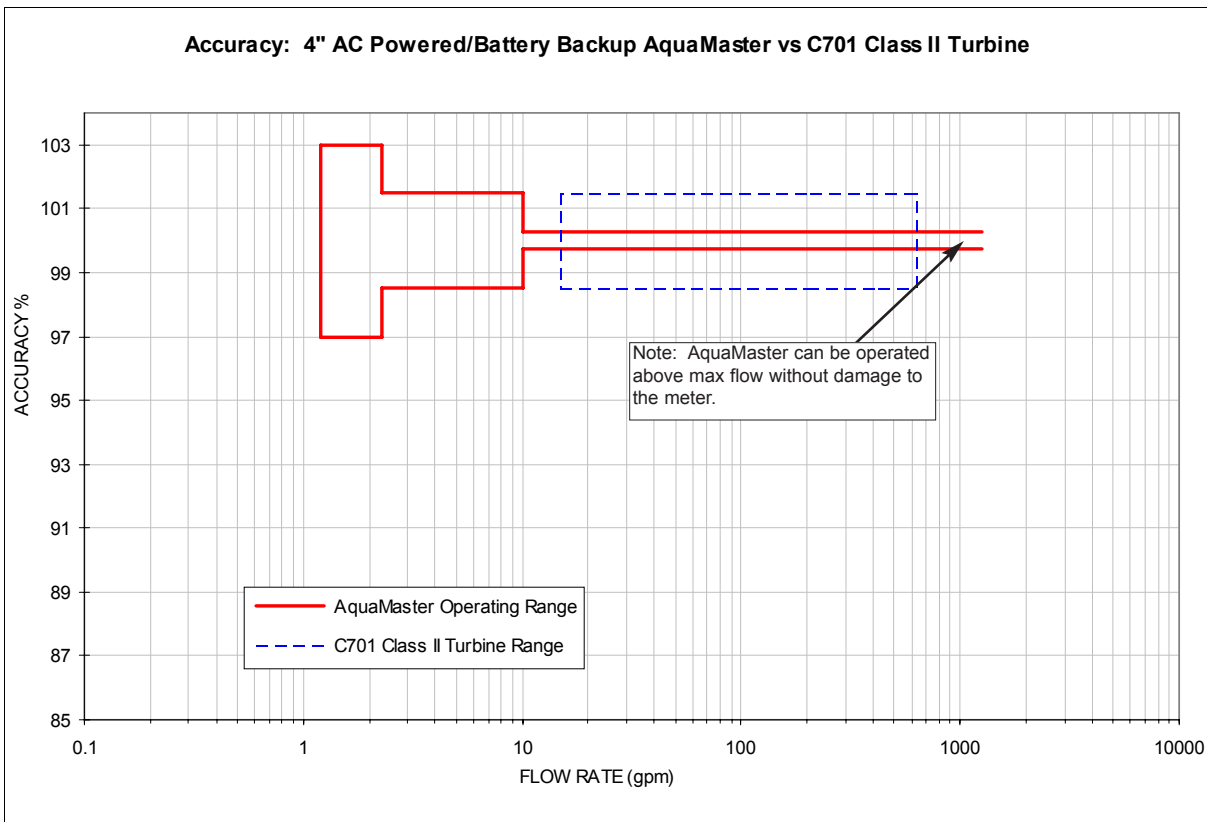
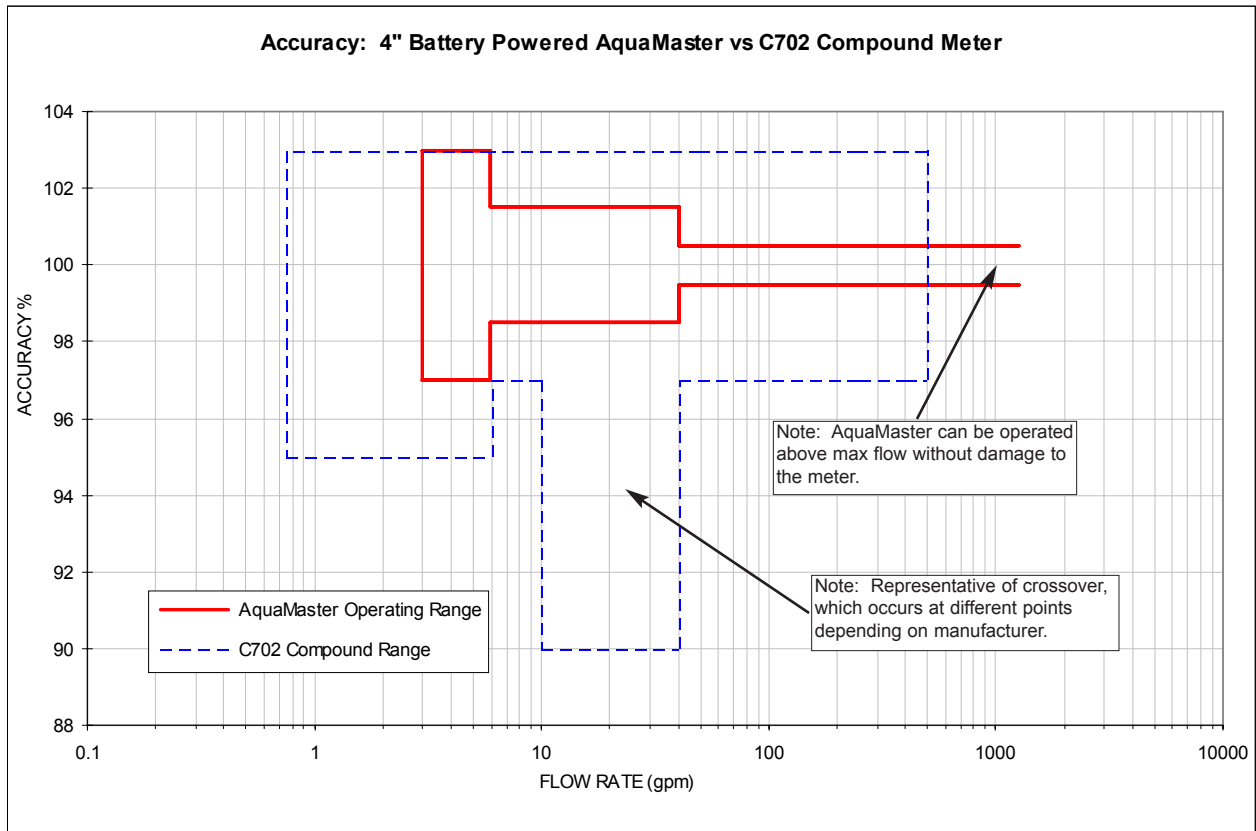

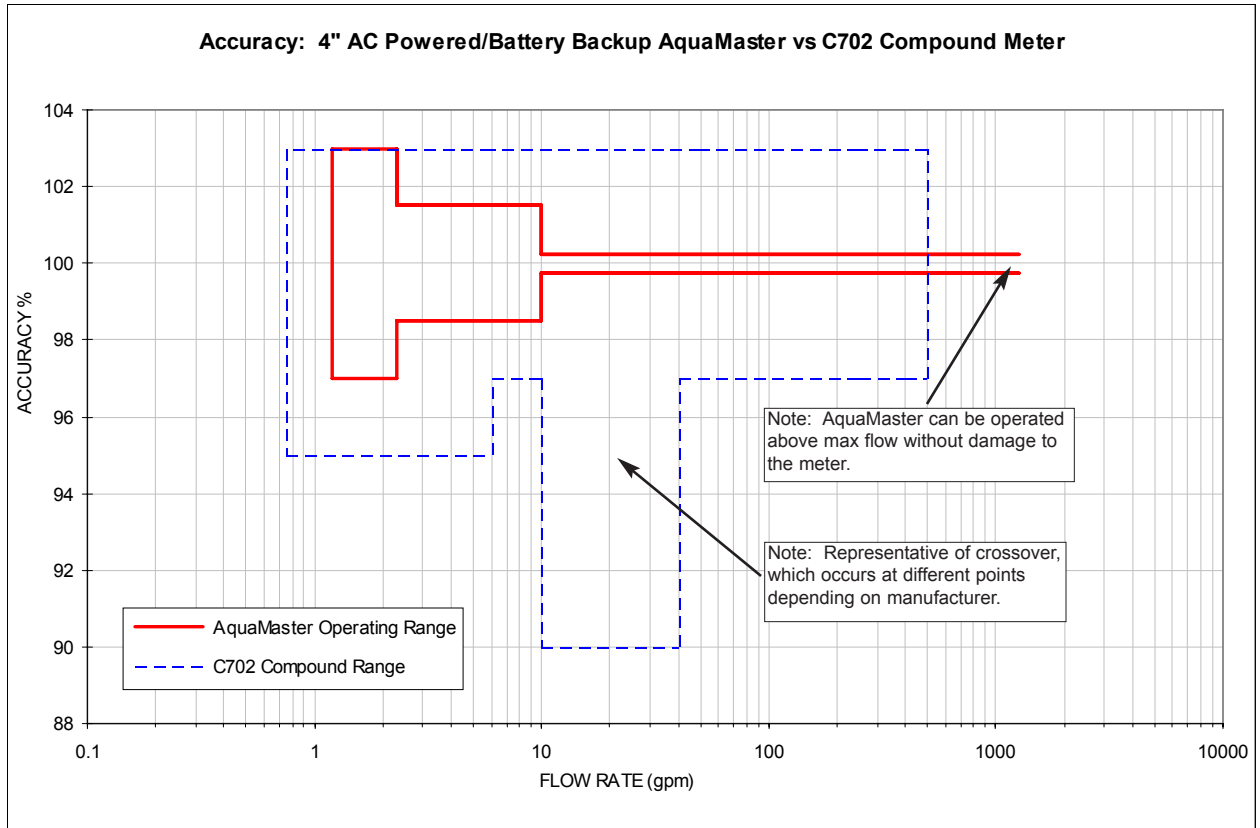

General Specification

AquaMaster - Operating Parameters

	Maximum Flow (gpm) AC: 99.75%-100.25% Bat: 99.5%-100.5%	Continuous Duty Flow (gpm) AC: 99.75%-100.25% Bat: 99.5%-100.5%	Accuracy AC Powered			Accuracy Battery Powered			Head Loss at Continuous Flow (psi)
			Low Flow (gpm) 97%-103%	Low Flow (gpm) 98.5%-101.5%	Normal Flow (gpm) 99.75%-100.25%	Low Flow (gpm) 97%-103%	Low Flow (gpm) 98.5%-101.5%	Normal Flow (gpm) 99.5%-100.5%	
5/8"	22	18	0.03	0.06	0.33	0.08	0.15	1.0	8.2
3/4"	35	28	0.05	0.09	0.55	0.12	0.23	1.7	7.1
1"	55	44	0.08	0.15	0.77	0.19	0.37	2.2	8.9
1 1/2"	136	110	0.19	0.37	6.60	0.46	0.92	6.6	7.1
2"	220	176	0.3	0.60	6.60	0.74	1.47	10.0	6.8
3"	756	440	0.8	1.50	8.80	1.84	3.67	26	7.0
4"	1,268	700	1.2	2.30	10	3.0	5.9	40	7.1
6"	2,838	1,760	3	6	30	7.5	15	101	8.9
8"	3,658	2,770	4.5	9	60	11.5	23	167	5.5
10"	5,855	4,400	7.5	15	90	18.5	37	264	6.9
12"	8,806	7,040	11.5	23	130	29.5	59	396	7.0
14"	8,806	7,040	23.5	47	352	73.5	147	528	3.5
16"	13,759	11,000	36.5	73	440	91.5	183	660	6.8
18"	19,263	15,400	51.5	103	570	128.5	257	859	8.3
20"	22,014	17,600	58.5	117	660	183.5	367	991	8.7
24"	34,673	27,700	92.5	185	1100	231.0	462	1651	5.3

AquaMaster Operating Parameters Compared to AWWA Class II Turbine Meters (C701)

	Maximum Flow		Continuous Duty Flow		Low Flow		Normal Flow	Head Loss at C701 SMOC	
	AquaMaster (gpm) AC: 99.75%-100.25% Bat: 99.5%-100.5%	C701-88 (gpm) 98.5% -101.5%	AquaMaster (gpm) AC: 99.75%-100.25% Bat: 99.5%-100.5%	C701-88 (gpm) 98.5%-101.5%	AquaMaster AC (gpm) 98.5%-101.5%	AquaMaster-Battery (gpm) 98.5%-101.5%	C701-88 (gpm) 98.5%-101.5%	AquaMaster (psi)	C701-88 (psi)
2"	220	160	176	100	0.6	1.47	4	5.63	7
3"	756	350	440	240	1.5	3.67	8	4.45	7
4"	1268	630	700	420	2.3	5.9	15	5.74	7
6"	2838	1400	1760	920	6	15	30	5.62	7
8"	3658	2400	2770	1600	9	23	50	4.11	7
10"	5855	3800	4400	2500	15	37	75	5.12	7
12"	8806	5000	7040	3300	23	59	120	3.54	7

AquaMaster Operating Parameters Compared to AWWA Compound Meters (C702) Part 1

	Maximum Flow		Continuous Duty Flow		Normal Flow
	AquaMaster (gpm) AC: 99.75% - 100.25% Bat: 99.5% - 100.5%	C702-92 (gpm) 97% -103%	AquaMaster (gpm) AC: 99.75%-100.25% Bat: 99.5% - 100.5%	C702-92 (gpm) 97% -103%	C702-92 (gpm) 97% - 103%
2"	220	160	176	80	2
3"	756	320	440	160	4
4"	1268	500	700	250	6
6"	2838	1000	1760	500	10
8"	3658	1600	2770	800	16
10"	5855	2300	4400	1150	32

AquaMaster Operating Parameters Compared to AWWA Compound Meters (C702) Part 2

	Low Flow				Head Loss at C702 SMOC		
	AquaMaster - AC (gpm)		AquaMaster - Battery (gpm)		C702-92 (gpm) 95% - 101%	AquaMaster (psi)	C702-92 (psi)
	97% - 103%	98.5% - 101.5%	97% - 103%	98.5% - 101.5%			
2"	0.3	0.6	0.7	1.47	0.25	5.63	20
3"	0.8	1.5	1.8	3.67	0.5	3.72	20
4"	1.2	2.3	3.0	5.9	0.75	3.62	20
6"	3	6	7.5	15	1.5	2.87	20
8"	4.5	9	11.5	23	2	1.83	20
10"	7.5	15	18.5	37	4	1.88	20

...General Specification

Wetted Materials

Screw End Meters (5/8" - 1")
Brass

Flanged meters (1 1/2" - 24")
Stainless Steel

Electrodes
Stainless Steel 316L

Lining
Suitable for potable water

Pressure Limitations
As flange rating

Conductivity
>50µS/cm

End Connections

Thread end connections
5/8" meter - 3/4" NPSM
3/4" meter - 1" NPSM
1" meter - 1 1/4" NPSM

1 1/2" to 12" (40 to 300mm) flanged
ANSI B16.5 1.5 Class 150
BS4504/ISO 7005 - PN16, PN10
AS 2129 Tables C, D and E
AS 4087/14, AS4087/16
JIS to BS2210, 5k, 10k and 30k
BS10 Tables D and E

14" to 24" (350 to 600mm) flanged
ANSI B16.5 1.5 Class 150
BS4504/ISO 7005 - PN10, PN16

Electronic Display Unit

Mounting
Integral with sensor
or
Remote up to 650 ft (200m)

Housing
IP68 (NEMA 6P) Aluminum Alloy with Glass Window

Electrical Connections
20/16mm plastic glands, 20mm armored, or accepts 1/2 in. NPT threaded or military style plug & socket

Sensor Cable
AMCO WMS cable supplied as standard
SWA cable available on application

Power Supply
Battery life @ 32° to 122°F (0 to 50°C)
1 battery - typically 1.2 years
2 batteries - typically 3 years (28 months for 14" or larger)

Type	Voltage Range (V) Absolute Rating	Frequency (Hz)	VA
AC	85 to 265	47 to 440	<10
Battery	3.6 (Lithium)	-	-

Temperature Ranges

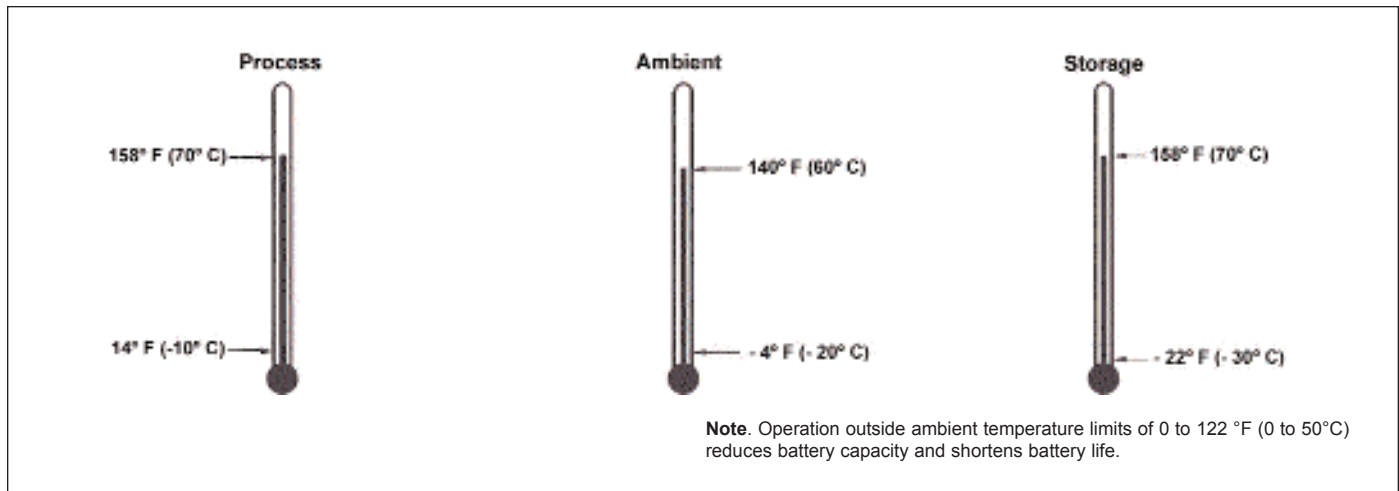

...Electronic Display Unit

Pulse and Alarm Outputs

Three bi-directional solid state switches with common isolation $\pm 35V$ DC 50mA.

Output 1 Forward only, or forward plus reverse pulses

Output 2 Reverse pulses, or direction indicator

Output 3 Alarm indicates any problems with the measurement or unit power

Pulse output 50Hz maximum, 50% nominal duty cycle

Serial Data Communications

Local Port RS232 compatible via AMCO WMS lead (Option)

Remote Port (Option) RS232 with RI, RTS and CTS handshaking for connection to a modem or computer

Telemetry applications using remote serial data communications

External PSTN modem Modem PSTN modems which store configuration setup on non-volatile memory (for configuration information contact AMCO Water)

Pressure System - Optional External Transducer

Pressure range absolute

10, 16bar or 300 lb/in²

Connection

Standard quick-fit male probe
MIL style connector

Operating temperature range

-4 to 158°F (-20 to 70°C)

Accuracy (typical)

$\pm 0.4\%$ of range

Thermal error band (typically 212°F [100°C])

$\pm 1.5\%$ span

Cable length

3, 16 or 32 ft (1, 5, 10 or 20m)

Logger details

	Logger		
	1	2	3
Logger Function	Flow & Pressure	Flow & Pressure	Forward, Reverse & Net Flow Totals
No. of Records	8831	11361	366
Logging Interval	15 to 65500s (adjustable)		24 hours (fixed)
Typical Capacity	3 months @ 15min.	~7 days @ 1 min.	1 year
Mode	Cyclic	Cyclic	Cyclic
Use ABB LogMaster	4	4	4
Use Technolog (PMAC)	4	4	8
Use Primayer Primeware	4	4	8
Use OSI PI Database/IBV (WADIS) System	4	4	8

Response Time (Programmable)

Minimum

1s (AC powered)

15s (battery powered)

Languages

English

French

Spanish

Languages can be changed via Windows download program (contact AMCO Water)

...General Specification

Mounting

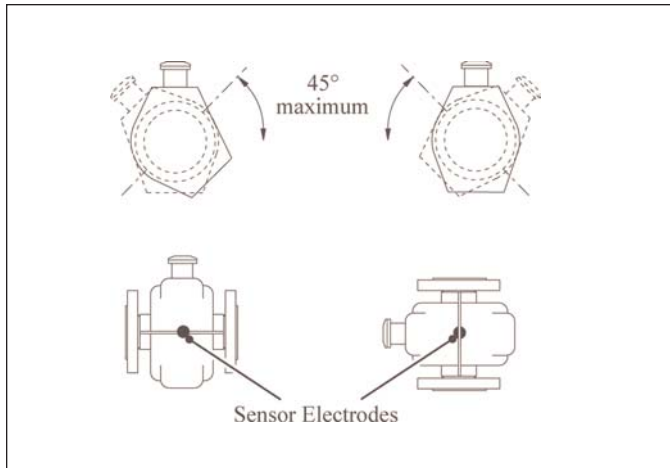

Pipe Conditions

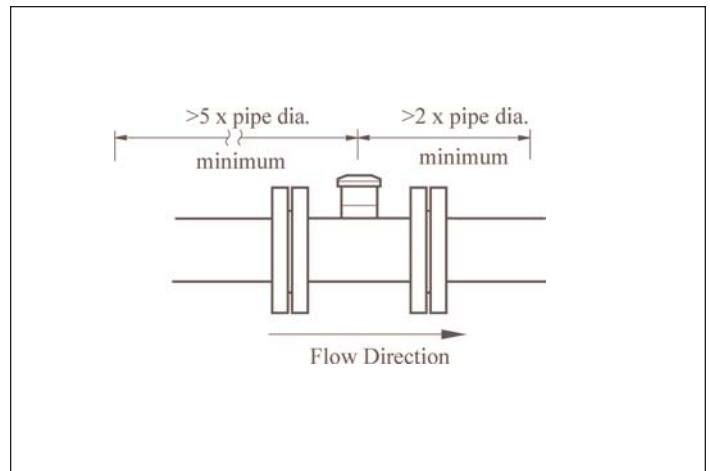

Default Settings Table

Configuration Parameter	Default North America
Pulse Factor	1
Pulse Units	Ugal
Totalizer Units	Ugal
Full Scale Flow	Iso 4064 Qn
Flow Units	MUGD
Velocity Units	ft/s
Date Format from Country Code	MMDDYY
Flow Response Time (s)	3
Display Flow Rate	Yes
Display Forward Total	Yes
Display Reverse Total	Yes
Display Net Total	No
Display Date	No
Display Velocity	No
Output Option Pulse Forward	Pulses Forward
Output Option Pulse Reverse	Pulses Reverse
Profile Factor	1
Probe Insertion Factor	1

Sensor Specification (nominal dimensions)

5/8" to 1" (16 to 25mm) - Screw Ends

Meter Size		Dimensions in. (mm)	Connection	Approx. Weight	
in.	mm	A		lb	kg
5/8	16	4.7 (119)	G 3/4 in. B or 3/4 in. NPSM	5	2.5
3/4	20	5 (127)	G 1 in. B or 1 in. NPSM	5	2.5
1	25	5 (127)	G 1 1/4 in. B or 1 1/4 in. NPSM	5	2.5

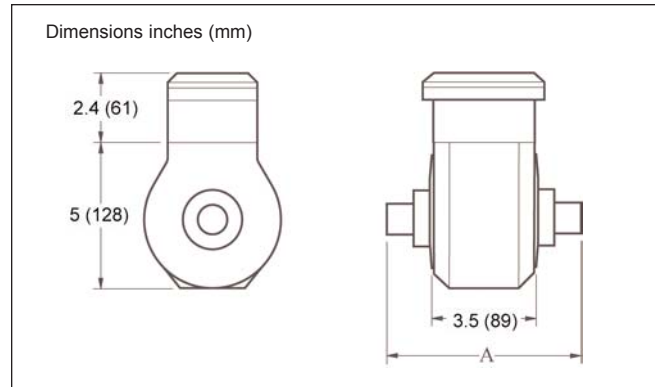

1 1/2" to 12" (40 to 300 mm) - Flanged

Meter Size		Dimensions in. (mm)		Approx. Weight	
in.	mm	A	B	lb	kg
1 1/2	40	7 (176)	7.9 (200)	20	9
2	50	7 (176)	7.9 (200)	23	10
3	80	8.6 (219)	7.9 (200)	40	18
4	100	9.1 (230.5)	9.8 (250)	54	24
6	150	11.1 (281)	11.8 (300)	84	38
8	200	15.8 (402)	13.8 (350)	81	37
10	250	17.3 (440)	17.7 (450)	132	60
12	300	18.9 (480)	19.7 (500)	154	70

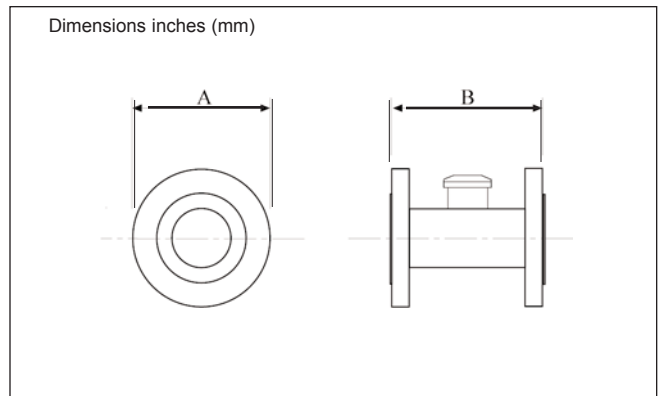

14" to 24" (350 to 600 mm) - Flanged

Meter Size		Dimensions in. (mm)			Approx. Weight	
in.	mm	A	B	C	lb	kg
14	350	20.2 (513)	20.5 (520)	21.7 (550)	220	100
16	400	22.4 (570)	22.7 (576)	23.6 (600)	253	115
18	450	24.9 (632)	24.7 (627)	27.5 (698)	352	160
20	500	27.0 (686)	26.7 (679)	30.2 (768)	455	217
24	600	30.4 (772)	30.3 (770)	36.1 (918)	693	315

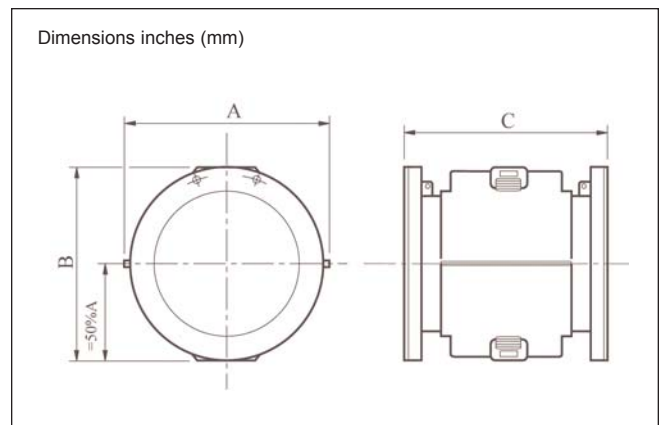

Overall Dimensions

Terminal Box - Sensor Mounted

Dimensions inches (mm)

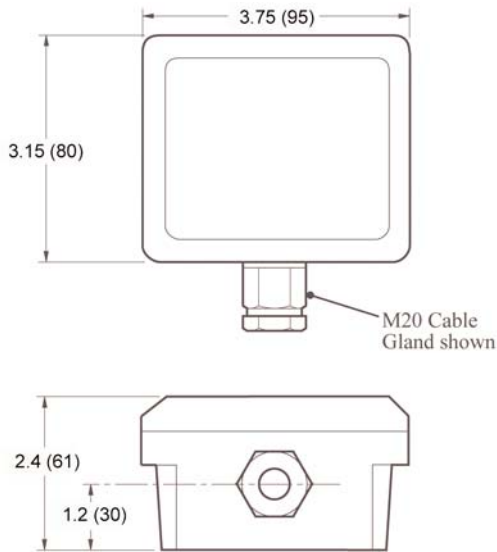

IP68/NEMA6P Electronic Display Unit

Dimension inches (mm)

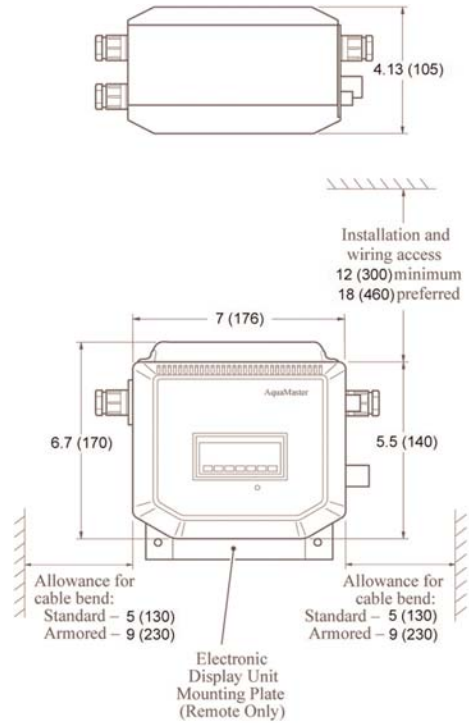

Note. For integral mounting, the Electronic Display Unit is supplied mounted on top of the terminal box.

Electrical Connections

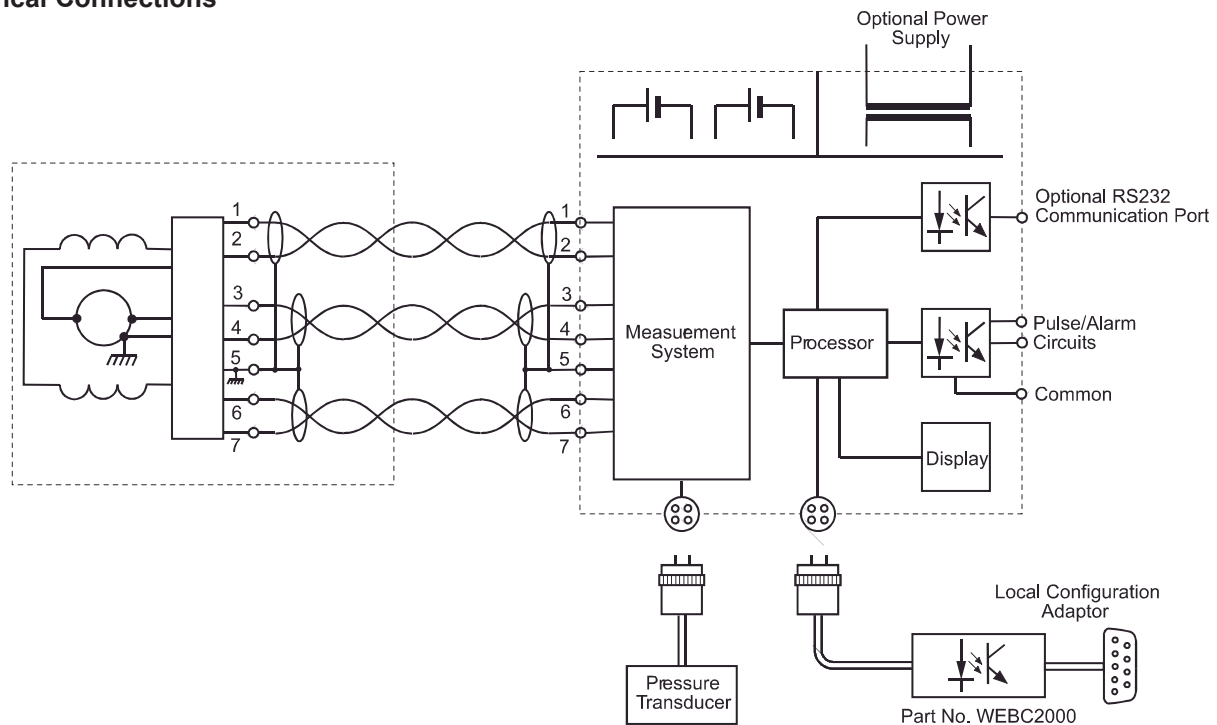

AMCO 

Distributed by:

www.watermeters.com

Daniel L. Jerman Co.

275 Railroad Place

Hackensack, NJ 07601

Phone 800.654.3733

Fax 201.487.3953

International Phone

201.487.7444

AMS-TS/12-03